

TORSION SPRINGS

Tolerances

Tolerances on Outside Diameter	
INCHES	MILLIMETERS
.093" – .125" ± .004"	2.36 – 3.17 ± .10mm
.126" – .200" ± .005"	3.18 – 5.08 ± .13mm
.201" – .300" ± .007"	5.09 – 7.62 ± .18mm
.301" – .410" ± .010"	7.63 – 10.41 ± .26mm
.411" – .500" ± .013"	10.42 – 12.70 ± .33mm
.501" – .700" ± .015"	12.71 – 17.78 ± .38mm
.701" – .875" ± .020"	17.79 – 22.23 ± .51mm
.876" – 1.125" ± .025"	22.24 – 28.58 ± .64mm
1.126" – 1.218" ± .030"	28.59 – 30.94 ± .76mm
1.219" – 1.250" ± .035"	30.95 – 31.75 ± .89mm
1.251" – 1.360" ± .040"	31.76 – 34.54 ± 1.02mm
1.361" – 1.520" ± .045"	34.55 – 38.60 ± 1.14mm
1.521" – 1.750" ± .050"	38.61 – 44.45 ± 1.27mm
1.751" – 2.000" ± .055"	44.46 – 50.80 ± 1.40mm
Over 2.000" ± .060"	Over 50.80 ± 1.52mm

Tolerances on Free Position:

From 3 to 10 total coils (Incl.) ± 10°
From 11 to 20 total coils (Incl.) ± 15°

TORSION SPRINGS

Guide to using tables

Radius
please note that R (radius) where force is applied, is always 1/2 of A (length of leg).
Dotted lines of legs show loaded position where values of T (Torque) will be achieved at R (Radius)

Length of Leg
lengths of leg are shown on A in the sketches below.

Outside Diameter
of spring body.

Suggested Mandrel
size allows approximately a 10% clearance for the various deflections shown in examples below. If greater deflections are required, we suggest a suitable reduction in mandrel size.

Price Group
reference to the price list

Number of Coils
total coils in each spring.

Body Length
overall length, see sketch below.

Lee Stock Number
Please add suffix **M** for Music Wire or **S** for 302 Stainless Steel when ordering.

Wire Diameter
in ascending order of size.

Maximum Torque
the greatest torque value capable for design. However, if properly mounted and the values shown under T (Torque) are reduced by approximately 20%, the life of the spring will be considerably improved (See note 6).

Deflection to Maximum Torque
the degrees of angular movement between the legs to achieve maximum torque.

LEE STOCK NUMBER	NOMINAL WIRE DIAMETER		(T) MAXIMUM TORQUE (footpounds)		DEFLECTION TO MAX. TORQUE (°)	(R) RADIUS		(A) LENGTH OF LEG		OUTSIDE DIAMETER		SUGGESTED MANDREL SIZE		(L) BODY LENGTH APPROX.		TOTAL NO. OF COILS	PRICE LIST	
	MM	IN	IN-LB	IN-LB		MM	IN	MM	IN	MM	IN	MM	IN	MM	IN		MM	IN
LTRO12A 01	0.30	0.012	5.65	0.050	90	4.76	0.188	9.53	0.375	2.67	0.105	1.65	0.065	1.37	0.054	3.25	L	M
LTRO12A 07			5.42	0.039	90	6.35	0.250	12.70	0.500	3.71	0.146	2.39	0.094	0.99	0.039	2.25	L	M
LTRO14A 01	0.36	0.014	8.47	0.075	90	6.35	0.250	12.70	0.500	3.15	0.124	1.57	0.062	1.65	0.065	3.25	L	M
LTRO14A 07			8.10	0.075	90	6.35	0.250	12.70	0.500	4.37	0.172	3.18	0.125	1.17	0.044	2.25	L	M
LTRO15B 01	0.38	0.015	11.30	0.100	90	6.35	0.250	12.70	0.500	2.82	0.111	1.57	0.062	1.73	0.068	3.25	L	M
LTRO15B 07			11.30	0.100	90	6.35	0.250	12.70	0.500	4.34	0.171	2.39	0.094	1.24	0.049	2.25	L	M
LTMR040A 01	0.40	0.016	9.97	0.088	68	8.00	0.315	16.00	0.630	2.80	0.110	1.50	0.059	2.01	0.079	4.25	L	M
LTMR040A 07			9.97	0.088	36	8.00	0.315	16.00	0.630	2.80	0.110	1.50	0.059	1.19	0.047	2.25	L	M
LTMR040C 01			9.97	0.088	96	8.00	0.315	16.00	0.630	3.80	0.150	2.50	0.098	2.01	0.079	4.25	L	M
LTMR040C 07			9.97	0.088	51	8.00	0.315	16.00	0.630	3.80	0.150	2.50	0.098	1.19	0.047	2.25	L	M
LTMR040G 01			9.97	0.088	153	8.00	0.315	16.00	0.630	5.80	0.228	4.00	0.157	2.01	0.079	4.25	L	M
LTMR040G 07			9.97	0.088	81	8.00	0.315	16.00	0.630	5.80	0.228	4.00	0.157	1.19	0.047	2.25	L	M
LTRO17C 01	0.43	0.017	14.12	0.125	90	6.35	0.250	12.70	0.500	4.06	0.160	2.36	0.093	1.96	0.077	3.25	L	M
LTRO17C 07			14.12	0.125	90	9.53	0.375	19.05	0.750	5.66	0.223	3.96	0.156	1.40	0.055	2.25	L	M
LTRO18C 01	0.46	0.018	16.95	0.150	90	6.35	0.250	12.70	0.500	4.52	0.178	2.77	0.109	2.03	0.080	3.25	L	M
LTRO18C 07			16.95	0.150	90	9.53	0.375	19.05	0.750	5.94	0.234	3.96	0.156	1.47	0.058	2.25	L	M
LTMR050B 01	0.50	0.020	17.90	0.159	64	10.00	0.394	20.00	0.787	3.50	0.138	2.00	0.079	2.49	0.098	4.25	L	M
LTMR050B 07			17.90	0.159	34	10.00	0.394	20.00	0.787	3.50	0.138	2.00	0.079	1.50	0.059	2.25	L	M
LTMR050E 01			17.90	0.159	86	10.00	0.394	20.00	0.787	4.50	0.177	3.00	0.118	2.49	0.098	4.25	L	M
LTMR050E 07			17.90	0.159	45	10.00	0.394	20.00	0.787	4.50	0.177	3.00	0.118	1.50	0.059	2.25	L	M
LTMR050I 01			17.90	0.159	139	10.00	0.394	20.00	0.787	7.00	0.276	5.00	0.197	2.49	0.098	4.25	L	M
LTMR050I 07			17.90	0.159	74	10.00	0.394	20.00	0.787	7.00	0.276	5.00	0.197	1.50	0.059	2.25	L	M
LTRO19C 01						9.53	0.375	19.05	0.750	4.85	0.191							

ADDITIONAL INFORMATION

- To translate torque values to direct load: Use $F = \frac{T}{R}$ Formula
F = Load applied at Radius R. T = Torque
- To calculate torque values other than those listed (Position of Ends), a direct proportion may be used.
- Inspection of Load. Loads should always be checked at the Radius (R value).
- Direction of Wind. Good design dictates that torsion springs should be used in the direction that winds the coil. When ordering be sure to specify either Left or Right Hand wind.
- Material specifications, finishes and tolerances are detailed on page 237.

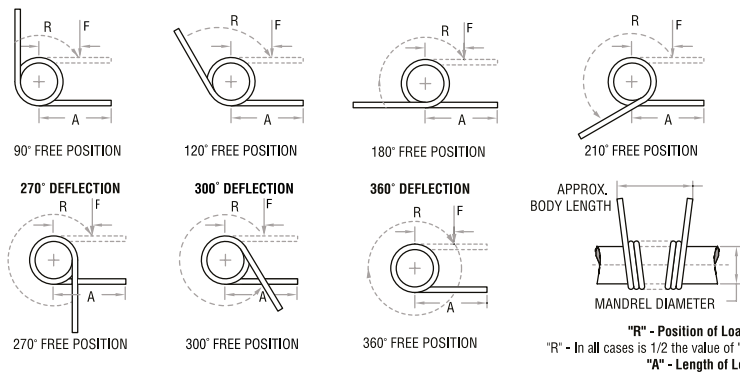

- Please note that the torque listed in the following torsion spring tables relates only to music wire.
When choosing stainless steel multiply the factors by 0.933.

TORSION SPRINGS



90°

● Left Hand or Right Helix

● Music Wire (Plated) or Stainless Steel (Passivated)

LEE STOCK NUMBER	NOMINAL WIRE DIAMETER		(T) MAXIMUM TORQUE (see footnotes)		DEFLECTION TO MAX. TORQUE DEG (°)	(R) RADIUS		(A) LENGTH OF LEG		OUTSIDE DIAMETER		SUGGESTED MANDREL SIZE		(L) BODY LENGTH APPROX.		TOTAL NO. OF COILS	PRICE LIST			
	MM	IN	N-MM	IN-LB		MM	IN	MM	IN	MM	IN	MM	IN	MM	IN		MM	IN	M	S
LTL012A 01 LTR012A 01	0.30	0.012	5.65	0.050	90	4.76	0.188	9.53	0.375	2.67	0.105	1.65	0.065	1.37	0.054	3.25	L	M		
LTL012A 07 LTR012A 07			5.42	0.048	90	6.35	0.250	12.70	0.500	3.71	0.146	2.39	0.094	0.99	0.039	2.25	L	M		
LTL014A 01 LTR014A 01	0.36	0.014	8.47	0.075	90	6.35	0.250	12.70	0.500	3.15	0.124	1.57	0.062	1.65	0.065	3.25	L	M		
LTL014A 07 LTR014A 07			8.47	0.075	90	6.35	0.250	12.70	0.500	4.37	0.172	3.18	0.125	1.17	0.046	2.25	L	M		
LTL015B 01 LTR015B 01	0.38	0.015	11.30	0.100	90	6.35	0.250	12.70	0.500	2.82	0.111	1.57	0.062	1.73	0.068	3.25	L	M		
LTL015B 07 LTR015B 07			11.30	0.100	90	6.35	0.250	12.70	0.500	4.34	0.171	2.39	0.094	1.24	0.049	2.25	L	M		
LTML040A 01 LTMR040A 01	0.40	0.016	9.97	0.088	68	8.00	0.315	16.00	0.630	2.80	0.110	1.50	0.059	2.01	0.079	4.25	L	M		
LTML040A 07 LTMR040A 07			9.97	0.088	36	8.00	0.315	16.00	0.630	2.80	0.110	1.50	0.059	1.19	0.047	2.25	L	M		
LTML040C 01 LTMR040C 01			9.97	0.088	96	8.00	0.315	16.00	0.630	3.80	0.150	2.50	0.098	2.01	0.079	4.25	L	M		
LTML040C 07 LTMR040C 07			9.97	0.088	51	8.00	0.315	16.00	0.630	3.80	0.150	2.50	0.098	1.19	0.047	2.25	L	M		
LTML040G 01 LTMR040G 01			9.97	0.088	153	8.00	0.315	16.00	0.630	5.80	0.228	4.00	0.157	2.01	0.079	4.25	L	M		
LTML040G 07 LTMR040G 07			9.97	0.088	81	8.00	0.315	16.00	0.630	5.80	0.228	4.00	0.157	1.19	0.047	2.25	L	M		
LTL017C 01 LTR017C 01			0.43	0.017	14.12	0.125	90	6.35	0.250	12.70	0.500	4.06	0.160	2.36	0.093	1.96	0.077	3.25	L	M
LTL017C 07 LTR017C 07					14.12	0.125	90	9.53	0.375	19.05	0.750	5.66	0.223	3.96	0.156	1.40	0.055	2.25	L	M
LTL018C 01 LTR018C 01	0.46	0.018	16.95	0.150	90	6.35	0.250	12.70	0.500	4.52	0.178	2.77	0.109	2.03	0.080	3.25	L	M		
LTL018C 07 LTR018C 07			16.95	0.150	90	9.53	0.375	19.05	0.750	5.94	0.234	3.96	0.156	1.47	0.058	2.25	L	M		
LTML050B 01 LTMR050B 01	0.50	0.020	17.90	0.159	64	10.00	0.394	20.00	0.787	3.50	0.138	2.00	0.079	2.49	0.098	4.25	L	M		
LTML050B 07 LTMR050B 07			17.90	0.159	34	10.00	0.394	20.00	0.787	3.50	0.138	2.00	0.079	1.50	0.059	2.25	L	M		
LTML050E 01 LTMR050E 01			17.90	0.159	86	10.00	0.394	20.00	0.787	4.50	0.177	3.00	0.118	2.49	0.098	4.25	L	M		
LTML050E 07 LTMR050E 07			17.90	0.159	45	10.00	0.394	20.00	0.787	4.50	0.177	3.00	0.118	1.50	0.059	2.25	L	M		
LTML050J 01 LTMR050J 01			17.90	0.159	139	10.00	0.394	20.00	0.787	7.00	0.276	5.00	0.197	2.49	0.098	4.25	L	M		
LTML050J 07 LTMR050J 07			17.90	0.159	74	10.00	0.394	20.00	0.787	7.00	0.276	5.00	0.197	1.50	0.059	2.25	L	M		
LTL020D 01 LTR020D 01			0.51	0.020	22.60	0.200	90	9.53	0.375	19.05	0.750	4.85	0.191	3.05	0.120	2.29	0.090	3.25	L	M
LTL020D 07 LTR020D 07	22.60	0.200			90	12.70	0.500	25.40	1.000	6.78	0.267	4.78	0.188	1.65	0.065	2.25	L	M		
LTL021D 01 LTR021D 01	0.53	0.021	28.25	0.250	90	9.53	0.375	19.05	0.750	5.08	0.200	3.05	0.120	2.41	0.095	3.25	L	M		
LTL021D 07 LTR021D 07			28.25	0.250	90	12.70	0.500	25.40	1.000	6.63	0.261	4.78	0.188	1.73	0.068	2.25	L	M		
LTL023D 01 LTR023D 01	0.58	0.023	37.28	0.330	90	9.53	0.375	19.05	0.750	5.18	0.204	3.18	0.125	2.62	0.103	3.25	L	K		
LTL023D 07 LTR023D 07			37.28	0.330	90	12.70	0.500	25.40	1.000	7.24	0.285	4.78	0.188	1.91	0.075	2.25	L	M		

TORSION SPRINGS

● Left Hand or Right Helix

● Music Wire (Plated) or Stainless Steel (Passivated)

LEE STOCK NUMBER	NOMINAL WIRE DIAMETER		(T) MAXIMUM TORQUE (see footnotes)		DEFLECTION TO MAX. TORQUE DEG (°)	(R) RADIUS		(A) LENGTH OF LEG		OUTSIDE DIAMETER		SUGGESTED MANDREL SIZE		(L) BODY LENGTH APPROX.		TOTAL NO. OF COILS	PRICE LIST			
	MM	IN	N-MM	IN-LB		MM	IN	MM	IN	MM	IN	MM	IN	MM	IN		Music wire	302 Stainless		
																	M	S		
LTML060D 01 LTMR060D 01	0.60	0.024	31.94	0.283	63	11.00	0.433	22.00	0.866	4.20	0.165	2.50	0.098	3.00	0.118	4.25	L	M		
LTML060D 07 LTMR060D 07			31.94	0.283	34	11.00	0.433	22.00	0.866	4.20	0.165	2.50	0.098	1.80	0.071	2.25	L	M		
LTML060H 01 LTMR060H 01			31.94	0.283	99	11.00	0.433	22.00	0.866	6.20	0.244	4.00	0.157	3.00	0.118	4.25	L	M		
LTML060H 07 LTMR060H 07			31.94	0.283	52	11.00	0.433	22.00	0.866	6.20	0.244	4.00	0.157	1.80	0.071	2.25	L	M		
LTML060L 01 LTMR060L 01			31.94	0.283	134	11.00	0.433	22.00	0.866	8.20	0.323	6.00	0.236	3.00	0.118	4.25	M	N		
LTML060L 07 LTMR060L 07			31.94	0.283	71	11.00	0.433	22.00	0.866	8.20	0.323	6.00	0.236	1.80	0.071	2.25	L	M		
LTL025E 01 LTR025E 01			0.64	0.025	47.45	0.420	90	9.53	0.375	19.05	0.750	5.99	0.236	3.56	0.140	2.79	0.110	3.25	L	M
LTL025E 07 LTR025E 07					47.45	0.420	90	12.70	0.500	25.40	1.000	7.92	0.312	5.56	0.219	2.06	0.081	2.25	M	N
LTL028E 01 LTR028E 01	0.71	0.028	62.14	0.550	90	12.70	0.500	25.40	1.000	6.78	0.267	4.45	0.175	3.18	0.125	3.25	M	N		
LTL028E 07 LTR028E 07			62.14	0.550	90	12.70	0.500	25.40	1.000	9.47	0.373	6.35	0.250	2.31	0.091	2.25	M	P		
LTML075F 01 LTMR075F 01	0.75	0.030	58.84	0.521	59	12.50	0.492	25.00	0.984	5.00	0.197	3.00	0.118	3.76	0.148	4.25	L	M		
LTML075F 07 LTMR075F 07			58.84	0.521	31	12.50	0.492	25.00	0.984	5.00	0.197	3.00	0.118	2.26	0.089	2.25	L	M		
LTML075K 01 LTMR075K 01			58.84	0.521	94	12.50	0.492	25.00	0.984	7.50	0.295	5.00	0.197	3.76	0.148	4.25	L	M		
LTML075K 07 LTMR075K 07			58.84	0.521	50	12.50	0.492	25.00	0.984	7.50	0.295	5.00	0.197	2.26	0.089	2.25	L	M		
LTML075Q 01 LTMR075Q 01			58.84	0.521	135	12.50	0.492	25.00	0.984	10.50	0.413	8.00	0.315	3.76	0.148	4.25	R	S		
LTML075Q 07 LTMR075Q 07			58.84	0.521	72	12.50	0.492	25.00	0.984	10.50	0.413	8.00	0.315	2.26	0.089	2.25	P	Q		
LTL030F 01 LTR030F 01			0.76	0.030	76.83	0.680	90	12.70	0.500	25.40	1.000	7.75	0.305	5.21	0.205	3.35	0.132	3.25	M	N
LTL030F 07 LTR030F 07					76.83	0.680	90	12.70	0.500	25.40	1.000	10.11	0.398	7.14	0.281	2.49	0.098	2.25	N	P
LTL032F 01 LTR032F 01	0.81	0.032	98.86	0.875	90	12.70	0.500	25.40	1.000	7.32	0.288	4.57	0.180	3.68	0.145	3.25	M	N		
LTL032F 07 LTR032F 07			98.86	0.875	90	12.70	0.500	25.40	1.000	10.21	0.402	7.14	0.281	2.64	0.104	2.25	N	P		
LTL035G 01 LTR035G 01	0.89	0.035	120.89	1.070	90	15.88	0.625	31.75	1.250	8.03	0.316	4.75	0.187	3.89	0.153	3.25	M	N		
LTL035G 07 LTR035G 07			120.89	1.070	90	15.88	0.625	31.75	1.250	11.89	0.468	8.74	0.344	2.90	0.114	2.25	Q	R		
LTL038G 01 LTR038G 01	0.97	0.038	144.62	1.280	90	15.88	0.625	31.75	1.250	9.80	0.386	6.35	0.250	4.32	0.170	3.25	N	P		
LTL038G 07 LTR038G 07			144.62	1.280	90	15.88	0.625	31.75	1.250	13.74	0.541	10.31	0.406	3.15	0.124	2.25	S	T		
LTML100J 01 LTMR100J 01	1.00	0.039	136.12	1.205	61	17.50	0.689	35.00	1.378	7.00	0.276	4.00	0.157	5.00	0.197	4.25	L	M		
LTML100J 07 LTMR100J 07			136.12	1.205	32	17.50	0.689	35.00	1.378	7.00	0.276	4.00	0.157	3.00	0.118	2.25	L	M		
LTML100N 01 LTMR100N 01			136.12	1.205	81	17.50	0.689	35.00	1.378	9.00	0.354	6.00	0.236	5.00	0.197	4.25	N	P		
LTML100N 07 LTMR100N 07			136.12	1.205	43	17.50	0.689	35.00	1.378	9.00	0.354	6.00	0.236	3.00	0.118	2.25	M	N		
LTML100T 01 LTMR100T 01			136.12	1.205	132	17.50	0.689	35.00	1.378	14.00	0.551	10.00	0.394	5.00	0.197	4.25	U	V		
LTML100T 07 LTMR100T 07			136.12	1.205	70	17.50	0.689	35.00	1.378	14.00	0.551	10.00	0.394	3.00	0.118	2.25	T	U		

TORSION SPRINGS

90°

● Left Hand or Right Helix

● Music Wire (Plated) or Stainless Steel (Passivated)

LEE STOCK NUMBER	NOMINAL WIRE DIAMETER		(T) MAXIMUM TORQUE (see footnotes)		DEFLECTION TO MAX. TORQUE DEG (°)	(R) RADIUS		(A) LENGTH OF LEG		OUTSIDE DIAMETER		SUGGESTED MANDREL SIZE		(L) BODY LENGTH APPROX.		TOTAL NO. OF COILS	PRICE LIST			
	MM	IN	N-MM	IN-LB		MM	IN	MM	IN	MM	IN	MM	IN	MM	IN		MM	IN	M	S
LTL040H 01 LTR040H 01	1.02	0.040	169.48	1.500	90	15.88	0.625	31.75	1.250	8.51	0.335	5.38	0.212	5.59	0.220	4.25	M	N		
LTL040H 07 LTR040H 07			169.48	1.500													90	12.70	0.500	25.40
LTL045H 01 LTR045H 01	1.14	0.045	242.92	2.150	90	15.88	0.625	31.75	1.250	9.04	0.356	5.72	0.225	6.22	0.245	4.25	N	P		
LTL045H 07 LTR045H 07			242.92	2.150													90	15.88	0.625	31.75
LTL048J 01 LTR048J 01	1.22	0.048	310.71	2.750	90	15.88	0.625	31.75	1.250	9.86	0.388	6.75	0.266	6.60	0.260	4.25	N	P		
LTL048J 07 LTR048J 07			310.71	2.750													90	15.88	0.625	31.75
LTML125M 01 LTMR125M 01	1.25	0.049	255.09	2.258	57	20.00	0.787	40.00	1.575	8.50	0.335	5.00	0.197	6.25	0.246	4.25	N	P		
LTML125M 07 LTMR125M 07			255.09	2.258	30	20.00	0.787	40.00	1.575	8.50	0.335	5.00	0.197	3.76	0.148	2.25	M	N		
LTML125R 01 LTMR125R 01			255.09	2.258	80	20.00	0.787	40.00	1.575	11.50	0.453	8.00	0.315	6.25	0.246	4.25	R	S		
LTML125R 07 LTMR125R 07			255.09	2.258	42	20.00	0.787	40.00	1.575	11.50	0.453	8.00	0.315	3.76	0.148	2.25	R	S		
LTML125V 01 LTMR125V 01			255.09	2.258	119	20.00	0.787	40.00	1.575	16.50	0.650	12.00	0.472	6.25	0.246	4.25	W	Y		
LTML125V 07 LTMR125V 07			255.09	2.258	63	20.00	0.787	40.00	1.575	16.50	0.650	12.00	0.472	3.76	0.148	2.25	V	X		
LTL051J 01 LTR051J 01			1.30	0.051	350.25	3.100	90	25.40	1.000	50.80	2.000	10.36	0.408	6.35	0.250	6.99	0.275	4.25	Q	R
LTL051J 07 LTR051J 07					350.25	3.100													90	15.88
LTL054K 01 LTR054K 01			1.37	0.054	395.45	3.500	90	25.40	1.000	50.80	2.000	12.29	0.484	8.00	0.315	7.49	0.295	4.25	R	R
LTL054K 07 LTR054K 07					395.45	3.500													90	15.88
LTL059K 01 LTR059K 01	1.50	0.059	508.43	4.500	90	25.40	1.000	50.80	2.000	12.67	0.499	7.92	0.312	8.13	0.320	4.25	S	T		
LTL059K 07 LTR059K 07			508.43	4.500													90	25.40	1.000	50.80
LTML150P 01 LTMR150P 01			425.51	3.767	53	22.50	0.886	45.00	1.772	10.00	0.394	6.00	0.236	7.49	0.295	4.25	P	Q		
LTML150P 07 LTMR150P 07			425.51	3.767	28	22.50	0.886	45.00	1.772	10.00	0.394	6.00	0.236	4.50	0.177	2.25	P	Q		
LTML150U 01 LTMR150U 01			425.51	3.767	85	22.50	0.886	45.00	1.772	15.00	0.591	10.00	0.394	7.49	0.295	4.25	V	W		
LTML150U 07 LTMR150U 07			425.51	3.767	45	22.50	0.886	45.00	1.772	15.00	0.591	10.00	0.394	4.50	0.177	2.25	U	V		
LTML150X 01 LTMR150X 01			425.51	3.767	116	22.50	0.886	45.00	1.772	20.00	0.787	15.00	0.591	7.49	0.295	4.25	X	Z		
LTML150X 07 LTMR150X 07			425.51	3.767	62	22.50	0.886	45.00	1.772	20.00	0.787	15.00	0.591	4.50	0.177	2.25	X	Z		
LTL063L 01 LTR063L 01			1.60	0.063	621.42	5.500	90	25.40	1.000	50.80	2.000	14.22	0.560	9.92	0.391	8.41	0.331	4.25	T	V
LTL063L 07 LTR063L 07					621.42	5.500													90	25.40
LTL070M 01 LTR070M 01	1.78	0.070	847.39	7.500	90	25.40	1.000	50.80	2.000	15.06	0.593	9.78	0.385	9.53	0.375	4.25	V	X		
LTL070M 07 LTR070M 07			847.39	7.500													90	25.40	1.000	50.80
LTL075M 01 LTR075M 01	1.91	0.075	1039.80	9.203	90	25.40	1.000	50.80	2.000	16.18	0.637	9.91	0.390	10.21	0.402	4.25	X	Z		
LTL075M 07 LTR075M 07			1039.80	9.203													90	25.40	1.000	50.80

TORSION SPRINGS

● Left Hand or Right Helix

● Music Wire (Plated) or Stainless Steel (Passivated)

LEE STOCK NUMBER	NOMINAL WIRE DIAMETER		(T) MAXIMUM TORQUE (see footnotes)		DEFLECTION TO MAX. TORQUE DEG (°)	(R) RADIUS		(A) LENGTH OF LEG		OUTSIDE DIAMETER		SUGGESTED MANDREL SIZE		(L) BODY LENGTH APPROX.		TOTAL NO. OF COILS	PRICE LIST			
	MM	IN	N-MM	IN-LB		MM	IN	MM	IN	MM	IN	MM	IN	MM	IN		Music wire	302 Stainless		
																M	S			
LTL078N 01 LTR078N 01	1.98	0.078	1180.69	10.450	90	25.40	1.000	50.80	2.000	16.69	0.657	10.21	0.402	10.62	0.418	4.25	Z	BB		
LTL078N 07 LTR078N 07			1180.69	10.450													90	25.40	1.000	50.80
LTML200S 01 LTMR200S 01	2.00	0.079	978.56	8.663	50	30.00	1.181	60.00	2.362	13.00	0.512	8.00	0.315	10.01	0.394	4.25	T	U		
LTML200S 07 LTMR200S 07			978.56	8.663	27	30.00	1.181	60.00	2.362	13.00	0.512	8.00	0.315	5.99	0.236	2.25	T	U		
LTML200W 01 LTMR200W 01			978.56	8.663	73	30.00	1.181	60.00	2.362	18.00	0.709	12.00	0.472	10.01	0.394	4.25	X	Z		
LTML200W 07 LTMR200W 07			978.56	8.663	39	30.00	1.181	60.00	2.362	18.00	0.709	12.00	0.472	5.99	0.236	2.25	X	Z		
LTML200Y 01 LTMR200Y 01			978.56	8.663	114	30.00	1.181	60.00	2.362	27.00	1.063	20.00	0.787	10.01	0.394	4.25	Z	BA		
LTML200Y 07 LTMR200Y 07			978.56	8.663	60	30.00	1.181	60.00	2.362	27.00	1.063	20.00	0.787	5.99	0.236	2.25	Y	BA		
LTL085N 01 LTR085N 01			2.16	0.085	1453.10	12.861	90	31.75	1.250	63.50	2.500	19.00	0.748	11.86	0.467	11.56	0.455	4.25	BB	BD
LTL085N 07 LTR085N 07					1452.98	12.860													90	31.75
LTL095P 01 LTR095P 01	2.41	0.095	1937.46	17.148	90	38.10	1.500	76.20	3.000	22.12	0.871	14.07	0.554	12.93	0.509	4.25	BD	BF		
LTL095P 07 LTR095P 07			1936.56	17.140													90	38.10	1.500	76.20
LTL105Q 01 LTR105Q 01	2.67	0.105	2372.68	21.000	90	44.45	1.750	88.90	3.500	21.54	0.848	12.70	0.500	16.67	0.656	5.25	BE	BG		
LTL105Q 07 LTR105Q 07			2372.68	21.000													90	44.45	1.750	88.90
LTL115R 01 LTR115R 01	2.92	0.115	3163.58	28.000	90	50.80	2.000	101.60	4.000	24.84	0.978	15.09	0.594	18.25	0.719	5.25	BF	BH		
LTL115R 07 LTR115R 07			3163.58	28.000													90	50.80	2.000	101.60
LTL125S 01 LTR125S 01	3.18	0.125	3615.51	32.000	90	50.80	2.000	101.60	4.000	25.12	0.989	15.01	0.591	23.02	0.906	6.25	BG	BJ		
LTL125S 07 LTR125S 07			3615.51	32.000													90	50.80	2.000	101.60
LTL135T 01 LTR135T 01	3.43	0.135	4519.39	40.000	90	50.80	2.000	101.60	4.000	27.99	1.102	16.92	0.666	24.84	0.978	6.25	BJ	BL		
LTL135T 07 LTR135T 07			4519.39	40.000													90	50.80	2.000	101.60

TORSION SPRINGS



● Left Hand or Right Helix

● Music Wire (Plated) or Stainless Steel (Passivated)

LEE STOCK NUMBER	NOMINAL WIRE DIAMETER		(T) MAXIMUM TORQUE (see footnotes)		DEFLECTION TO MAX. TORQUE DEG (°)	(R) RADIUS		(A) LENGTH OF LEG		OUTSIDE DIAMETER		SUGGESTED MANDREL SIZE		(L) BODY LENGTH APPROX.		TOTAL NO. OF COILS	PRICE LIST	
	MM	IN	N-MM	IN-LB		MM	IN	MM	IN	MM	IN	MM	IN	MM	IN		Music Wire	302 Stainless
																	M	S
LTL016A 10 LTR016A 10	0.41	0.016	12.43	0.110	120	9.53	0.375	19.05	0.750	4.83	0.190	3.18	0.125	1.70	0.067	3.17	M	N
LTL020B 10 LTR020B 10	0.51	0.020	20.34	0.180	120	12.70	0.500	25.40	1.000	6.93	0.273	4.75	0.187	2.11	0.083	3.17	N	P
LTL024C 10 LTR024C 10	0.61	0.024	31.64	0.280	120	12.70	0.500	25.40	1.000	9.19	0.362	6.35	0.250	2.54	0.100	3.17	P	Q
LTL026C 10 LTR026C 10	0.66	0.026	42.93	0.380	120	12.70	0.500	25.40	1.000	9.30	0.366	6.35	0.250	2.74	0.108	3.17	P	Q
LTL029C 10 LTR029C 10	0.74	0.029	53.10	0.470	120	12.70	0.500	25.40	1.000	9.27	0.365	6.35	0.250	3.81	0.150	4.17	P	Q
LTL032C 10 LTR032C 10	0.81	0.032	77.96	0.690	120	12.70	0.500	25.40	1.000	9.42	0.371	6.35	0.250	4.19	0.165	4.17	Q	Q
LTL035C 10 LTR035C 10	0.89	0.035	108.47	0.960	120	15.88	0.625	31.75	1.250	9.58	0.377	6.35	0.250	4.60	0.181	4.17	Q	Q
LTL038E 10 LTR038E 10	0.97	0.038	136.71	1.210	120	15.88	0.625	31.75	1.250	13.89	0.547	9.53	0.375	4.01	0.158	3.17	S	S
LTL040E 10 LTR040E 10	1.02	0.040	167.22	1.480	120	15.88	0.625	31.75	1.250	14.02	0.552	9.53	0.375	4.24	0.167	3.17	S	T
LTL042D 10 LTR042D 10	1.07	0.042	175.13	1.550	120	25.40	1.000	50.80	2.000	11.86	0.467	7.92	0.312	5.51	0.217	4.17	Q	R
LTL045D 10 LTR045D 10	1.14	0.045	229.36	2.030	120	25.40	1.000	50.80	2.000	12.04	0.474	7.92	0.312	5.92	0.233	4.17	Q	R
LTL049E 10 LTR049E 10	1.24	0.049	276.81	2.450	120	25.40	1.000	50.80	2.000	14.20	0.559	9.53	0.375	6.43	0.253	4.17	S	T
LTL055E 10 LTR055E 10	1.40	0.055	357.03	3.160	120	25.40	1.000	50.80	2.000	14.33	0.564	9.53	0.375	8.61	0.339	5.17	S	T
LTL059E 10 LTR059E 10	1.50	0.059	468.89	4.150	120	25.40	1.000	50.80	2.000	14.53	0.572	9.53	0.375	9.25	0.364	5.17	T	T
LTL063E 10 LTR063E 10	1.59	0.063	512.95	4.540	120	25.40	1.000	50.80	2.000	14.61	0.575	9.53	0.375	11.38	0.448	6.17	T	U
LTL072F 10 LTR072F 10	1.83	0.072	803.32	7.110	120	25.40	1.000	50.80	2.000	19.02	0.749	12.70	0.500	11.28	0.444	5.17	W	W
LTL080F 10 LTR080F 10	2.03	0.080	1060.93	9.390	120	31.75	1.250	63.50	2.500	19.33	0.761	12.70	0.500	14.55	0.573	6.17	X	Y
LTL085G 10 LTR085G 10	2.16	0.085	1255.26	11.110	120	31.75	1.250	63.50	2.500	23.52	0.926	15.88	0.625	13.31	0.524	5.17	Y	Y
LTL092G 10 LTR092G 10	2.32	0.092	1687.99	14.940	120	38.10	1.500	76.20	3.000	23.88	0.940	15.88	0.625	14.33	0.564	5.17	Y	Y
LTL095G 10 LTR095G 10	2.41	0.095	1991.92	17.630	120	38.10	1.500	76.20	3.000	24.10	0.949	15.88	0.625	14.88	0.586	5.17	Y	Y
LTL105H 10 LTR105H 10	2.67	0.105	2404.32	21.280	120	44.45	1.750	88.90	3.500	28.37	1.117	19.05	0.750	16.46	0.648	5.17	Y	Z
LTL112H 10 LTR112H 10	2.84	0.112	3060.76	27.090	120	50.80	2.000	101.60	4.000	28.75	1.132	19.05	0.750	17.55	0.691	5.17	Z	Z
LTL125H 10 LTR125H 10	3.18	0.125	3981.59	35.240	120	50.80	2.000	101.60	4.000	29.16	1.148	19.05	0.750	22.76	0.896	6.17	Z	BA
LTL135H 10 LTR135H 10	3.43	0.135	4659.49	41.240	120	50.80	2.000	101.60	4.000	29.51	1.162	19.05	0.750	28.02	1.103	7.17	BA	BA

TORSION SPRINGS

● Left Hand or Right Helix

● Music Wire (Plated) or Stainless Steel (Passivated)

LEE STOCK NUMBER	NOMINAL WIRE DIAMETER		(T) MAXIMUM TORQUE (see footnotes)		DEFLECTION TO MAX. TORQUE DEG (°)	(R) RADIUS		(A) LENGTH OF LEG		OUTSIDE DIAMETER		SUGGESTED MANDREL SIZE		(L) BODY LENGTH APPROX.		TOTAL NO. OF COILS	PRICE LIST			
	MM	IN	N-MM	IN-LB		MM	IN	MM	IN	MM	IN	MM	IN	MM	IN		Music Wire	302 Stainless		
																	M	S		
LTL012A 02 LTR012A 02	0.30	0.012	5.65	0.050	180	4.76	0.188	9.53	0.375	2.79	0.110	1.70	0.067	2.18	0.086	6.00	L	M		
LTL012A 04 LTR012A 04			5.65	0.050	180	6.35	0.250	12.70	0.500	4.24	0.167	2.77	0.109	1.50	0.059	4.00	L	M		
LTL014A 02 LTR014A 02	0.36	0.014	8.47	0.075	180	6.35	0.250	12.70	0.500	3.38	0.133	1.57	0.062	2.62	0.103	6.00	L	M		
LTL014A 04 LTR014A 04			8.47	0.075	180	9.53	0.375	19.05	0.750	4.93	0.194	2.77	0.109	1.91	0.075	4.00	L	M		
LTL015B 02 LTR015B 02	0.38	0.015	11.30	0.100	180	6.35	0.250	12.70	0.500	3.33	0.131	1.98	0.078	2.72	0.107	6.00	L	M		
LTL015B 04 LTR015B 04			11.30	0.100	180	9.53	0.375	19.05	0.750	4.67	0.184	2.77	0.109	1.91	0.075	4.00	L	M		
LTML040A 02 LTMR040A 02	0.40	0.016	9.97	0.088	192	8.00	0.315	16.00	0.630	2.80	0.110	1.50	0.059	5.21	0.205	12.00	L	M		
LTML040A 04 LTMR040A 04			9.97	0.088	48	8.00	0.315	16.00	0.630	2.80	0.110	1.50	0.059	1.60	0.063	3.00	L	M		
LTML040C 02 LTMR040C 02			9.97	0.088	272	8.00	0.315	16.00	0.630	3.80	0.150	2.50	0.098	5.21	0.205	12.00	L	M		
LTML040C 04 LTMR040C 04			9.97	0.088	68	8.00	0.315	16.00	0.630	3.80	0.150	2.50	0.098	1.60	0.063	3.00	L	M		
LTML040G 02 LTMR040G 02			9.97	0.088	432	8.00	0.315	16.00	0.630	5.80	0.228	4.00	0.157	5.21	0.205	12.00	L	M		
LTML040G 04 LTMR040G 04			9.97	0.088	108	8.00	0.315	16.00	0.630	5.80	0.228	4.00	0.157	1.60	0.063	3.00	L	M		
LTL017C 02 LTR017C 02			0.43	0.017	14.12	0.125	180	6.35	0.250	12.70	0.500	4.37	0.172	2.67	0.105	3.18	0.125	6.00	L	M
LTL017C 04 LTR017C 04					14.12	0.125	180	9.53	0.375	19.05	0.750	6.32	0.249	4.32	0.170	2.29	0.090	4.00	L	M
LTL018C 02 LTR018C 02			0.46	0.018	16.95	0.150	180	6.35	0.250	12.70	0.500	4.19	0.165	2.77	0.109	3.81	0.150	7.00	L	M
LTL018C 04 LTR018C 04					16.95	0.150	180	9.53	0.375	19.05	0.750	5.51	0.217	3.56	0.140	2.77	0.109	5.00	L	M
LTML050B 02 LTMR050B 02	0.50	0.020	17.90	0.159	181	10.00	0.394	20.00	0.787	3.50	0.138	2.00	0.079	6.50	0.256	12.00	L	M		
LTML050B 04 LTMR050B 04			17.90	0.159	45	10.00	0.394	20.00	0.787	3.50	0.138	2.00	0.079	2.01	0.079	3.00	L	M		
LTML050E 02 LTMR050E 02			17.90	0.159	242	10.00	0.394	20.00	0.787	4.50	0.177	3.00	0.118	6.50	0.256	12.00	L	M		
LTML050E 04 LTMR050E 04			17.90	0.159	60	10.00	0.394	20.00	0.787	4.50	0.177	3.00	0.118	2.01	0.079	3.00	L	M		
LTML050J 02 LTMR050J 02			17.90	0.159	391	10.00	0.394	20.00	0.787	7.00	0.276	5.00	0.197	6.50	0.256	12.00	M	N		
LTML050J 04 LTMR050J 04			17.90	0.159	98	10.00	0.394	20.00	0.787	7.00	0.276	5.00	0.197	2.01	0.079	3.00	M	N		
LTL020D 02 LTR020D 02	0.51	0.020	22.60	0.200	180	9.53	0.375	19.05	0.750	4.55	0.179	2.67	0.105	4.19	0.165	7.00	L	M		
LTL020D 04 LTR020D 04			22.60	0.200	180	12.70	0.500	25.40	1.000	6.15	0.242	4.06	0.160	3.18	0.125	5.00	L	M		
LTL021D 02 LTR021D 02	0.53	0.021	28.25	0.250	180	9.53	0.375	19.05	0.750	4.72	0.186	2.77	0.109	4.39	0.173	7.00	L	M		
LTL021D 04 LTR021D 04			28.25	0.250	180	12.70	0.500	25.40	1.000	6.30	0.248	3.96	0.156	3.23	0.127	5.00	L	M		
LTL023D 02 LTR023D 02	0.58	0.023	37.28	0.330	180	9.53	0.375	19.05	0.750	4.85	0.191	2.92	0.115	4.83	0.190	7.00	L	K		
LTL023D 04 LTR023D 04			37.28	0.330	180	12.70	0.500	25.40	1.000	6.58	0.259	4.32	0.170	3.68	0.145	5.00	L	M		

TORSION SPRINGS



● Left Hand or Right Helix

● Music Wire (Plated) or Stainless Steel (Passivated)

LEE STOCK NUMBER	NOMINAL WIRE DIAMETER		(T) MAXIMUM TORQUE (see footnotes)		DEFLECTION TO MAX. TORQUE	(R) RADIUS		(A) LENGTH OF LEG		OUTSIDE DIAMETER		SUGGESTED MANDREL SIZE		(L) BODY LENGTH APPROX.		TOTAL NO. OF COILS	PRICE LIST			
	MM	IN	N-MM	IN-LB		DEG (°)	MM	IN	MM	IN	MM	IN	MM	IN	MM		IN	M	S	
																			Music Wire	302 Stainless
LTML060D 02 LTMR060D 02	0.60	0.024	31.94	0.283	179	11.00	0.433	22.00	0.866	4.20	0.165	2.50	0.098	7.80	0.307	12.00	L	M		
LTML060D 04 LTMR060D 04			31.94	0.283	45	11.00	0.433	22.00	0.866	4.20	0.165	2.50	0.098	2.39	0.094	3.00	L	M		
LTML060H 02 LTMR060H 02			31.94	0.283	278	11.00	0.433	22.00	0.866	6.20	0.244	4.00	0.157	7.80	0.307	12.00	M	N		
LTML060H 04 LTMR060H 04			31.94	0.283	70	11.00	0.433	22.00	0.866	6.20	0.244	4.00	0.157	2.39	0.094	3.00	L	M		
LTML060L 02 LTMR060L 02			31.94	0.283	378	11.00	0.433	22.00	0.866	8.20	0.323	6.00	0.236	7.80	0.307	12.00	N	P		
LTML060L 04 LTMR060L 04			31.94	0.283	94	11.00	0.433	22.00	0.866	8.20	0.323	6.00	0.236	2.39	0.094	3.00	M	N		
LTL025E 02 LTR025E 02			0.64	0.025	47.45	0.420	180	9.53	0.375	19.05	0.750	5.72	0.225	3.56	0.140	5.23	0.206	7.00	L	M
LTL025E 04 LTR025E 04					47.45	0.420	180	12.70	0.500	25.40	1.000	7.75	0.305	5.16	0.203	3.84	0.151	5.00	L	M
LTL028E 02 LTR028E 02	0.71	0.028	62.14	0.550	180	12.70	0.500	25.40	1.000	6.32	0.249	3.96	0.156	5.97	0.235	7.00	M	N		
LTL028E 04 LTR028E 04			62.14	0.550	180	12.70	0.500	25.40	1.000	8.64	0.340	5.97	0.235	4.45	0.175	5.00	M	P		
LTML075F 02 LTMR075F 02	0.75	0.030	58.84	0.521	167	12.50	0.492	25.00	0.984	5.00	0.197	3.00	0.118	9.75	0.384	12.00	M	N		
LTML075F 04 LTMR075F 04			58.84	0.521	42	12.50	0.492	25.00	0.984	5.00	0.197	3.00	0.118	3.00	0.118	3.00	L	M		
LTML075K 02 LTMR075K 02			58.84	0.521	265	12.50	0.492	25.00	0.984	7.50	0.295	5.00	0.197	9.75	0.384	12.00	N	P		
LTML075K 04 LTMR075K 04			58.84	0.521	66	12.50	0.492	25.00	0.984	7.50	0.295	5.00	0.197	3.00	0.118	3.00	M	N		
LTML075Q 02 LTMR075Q 02			58.84	0.521	382	12.50	0.492	25.00	0.984	10.50	0.413	8.00	0.315	9.75	0.384	12.00	P	Q		
LTML075Q 04 LTMR075Q 04			58.84	0.521	96	12.50	0.492	25.00	0.984	10.50	0.413	8.00	0.315	3.00	0.118	3.00	P	Q		
LTL030F 02 LTR030F 02			0.76	0.030	76.83	0.680	180	12.70	0.500	25.40	1.000	6.93	0.273	4.37	0.172	6.30	0.248	7.00	M	N
LTL030F 04 LTR030F 04					76.83	0.680	180	12.70	0.500	25.40	1.000	10.03	0.395	6.35	0.250	4.60	0.181	5.00	M	P
LTL032F 02 LTR032F 02	0.81	0.032	98.86	0.875	180	12.70	0.500	25.40	1.000	6.86	0.270	4.32	0.170	6.73	0.265	7.00	M	N		
LTL032F 04 LTR032F 04			98.86	0.875	180	12.70	0.500	25.40	1.000	9.30	0.366	6.35	0.250	5.08	0.200	5.00	M	P		
LTL035G 02 LTR035G 02	0.89	0.035	120.89	1.070	180	15.88	0.625	31.75	1.250	7.72	0.304	4.75	0.187	7.37	0.290	7.00	M	N		
LTL035G 04 LTR035G 04			120.89	1.070	180	15.88	0.625	31.75	1.250	11.46	0.451	7.14	0.281	5.38	0.212	5.00	N	P		
LTL038G 02 LTR038G 02	0.97	0.038	144.62	1.280	180	15.88	0.625	31.75	1.250	9.22	0.363	6.10	0.240	8.00	0.315	7.00	N	P		
LTL038G 04 LTR038G 04			144.62	1.280	180	15.88	0.625	31.75	1.250	12.37	0.487	8.64	0.340	6.05	0.238	5.00	N	P		
LTML100J 02 LTMR100J 02	1.00	0.039	136.12	1.205	172	17.50	0.689	35.00	1.378	7.00	0.276	4.00	0.157	13.00	0.512	12.00	N	P		
LTML100J 04 LTMR100J 04			136.12	1.205	43	17.50	0.689	35.00	1.378	7.00	0.276	4.00	0.157	3.99	0.157	3.00	M	N		
LTML100N 02 LTMR100N 02			136.12	1.205	229	17.50	0.689	35.00	1.378	9.00	0.354	6.00	0.236	13.00	0.512	12.00	N	P		
LTML100N 04 LTMR100N 04			136.12	1.205	57	17.50	0.689	35.00	1.378	9.00	0.354	6.00	0.236	3.99	0.157	3.00	M	N		
LTML100T 02 LTMR100T 02			136.12	1.205	372	17.50	0.689	35.00	1.378	14.00	0.551	10.00	0.394	13.00	0.512	12.00	S	T		
LTML100T 04 LTMR100T 04			136.12	1.205	93	17.50	0.689	35.00	1.378	14.00	0.551	10.00	0.394	3.99	0.157	3.00	R	S		



TORSION SPRINGS

● Left Hand or Right Helix

● Music Wire (Plated) or Stainless Steel (Passivated)

LEE STOCK NUMBER	NOMINAL WIRE DIAMETER		(T) MAXIMUM TORQUE (see footnotes)		DEFLECTION TO MAX. TORQUE DEG (°)	(R) RADIUS		(A) LENGTH OF LEG		OUTSIDE DIAMETER		SUGGESTED MANDREL SIZE		(L) BODY LENGTH APPROX.		TOTAL NO. OF COILS	PRICE LIST			
	MM	IN	N-MM	IN-LB		MM	IN	MM	IN	MM	IN	MM	IN	MM	IN		Music Wire	302 Stainless		
																	M	S		
LTL040H 02 LTR040H 02	1.02	0.040	169.48	1.500	180	15.88	0.625	31.75	1.250	8.86	0.349	5.54	0.218	9.50	0.374	8.00	N	S		
LTL040H 04 LTR040H 04			169.48	1.500		180	25.40	1.000	50.80	2.000	13.18	0.519	8.71	0.343	6.15	0.242	5.00	N	P	
LTL045H 02 LTR045H 02	1.14	0.045	242.92	2.150	180	15.88	0.625	31.75	1.250	9.58	0.377	6.10	0.240	10.54	0.415	8.00	N	P		
LTL045H 04 LTR045H 04			242.92	2.150		180	25.40	1.000	50.80	2.000	14.61	0.575	9.91	0.390	7.11	0.280	5.00	N	P	
LTL048J 02 LTR048J 02	1.22	0.048	310.71	2.750	180	15.88	0.625	31.75	1.250	10.29	0.405	6.35	0.250	11.43	0.450	8.00	N	P		
LTL048J 04 LTR048J 04			310.71	2.750		180	25.40	1.000	50.80	2.000	15.72	0.619	10.31	0.406	7.42	0.292	5.00	Q	R	
LTML125M 02 LTMR125M 02	1.25	0.049	255.09	2.258	160	20.00	0.787	40.00	1.575	8.50	0.335	5.00	0.197	16.26	0.640	12.00	N	P		
LTML125M 04 LTMR125M 04			255.09	2.258	40	20.00	0.787	40.00	1.575	8.50	0.335	5.00	0.197	5.00	0.197	3.00	M	N		
LTML125R 02 LTMR125R 02			255.09	2.258	226	20.00	0.787	40.00	1.575	11.50	0.453	8.00	0.315	16.26	0.640	12.00	R	S		
LTML125R 04 LTMR125R 04			255.09	2.258	57	20.00	0.787	40.00	1.575	11.50	0.453	8.00	0.315	5.00	0.197	3.00	P	R		
LTML125V 02 LTMR125V 02			255.09	2.258	337	20.00	0.787	40.00	1.575	16.50	0.650	12.00	0.472	16.26	0.640	12.00	W	X		
LTML125V 04 LTMR125V 04			255.09	2.258	84	20.00	0.787	40.00	1.575	16.50	0.650	12.00	0.472	5.00	0.197	3.00	R	S		
LTL051J 02 LTR051J 02			1.30	0.051	350.25	3.100	180	25.40	1.000	50.80	2.000	10.92	0.430	6.99	0.275	11.94	0.470	8.00	Q	R
LTL051J 04 LTR051J 04					350.25	3.100		180	25.40	1.000	50.80	2.000	14.12	0.556	9.53	0.375	9.27	0.365	6.00	Q
LTL054K 02 LTR054K 02			1.37	0.054	395.45	3.500	180	25.40	1.000	50.80	2.000	12.93	0.509	8.76	0.345	12.70	0.500	8.00	R	R
LTL054K 04 LTR054K 04					395.45	3.500		180	25.40	1.000	50.80	2.000	16.61	0.654	11.68	0.460	9.91	0.390	6.00	R
LTL059K 02 LTR059K 02	1.50	0.059	508.43	4.500	180	25.40	1.000	50.80	2.000	13.36	0.526	8.51	0.335	13.72	0.540	8.00	S	T		
LTL059K 04 LTR059K 04			508.43	4.500		180	25.40	1.000	50.80	2.000	17.30	0.681	11.94	0.470	10.80	0.425	6.00	T	V	
LTML150P 02 LTMR150P 02			425.51	3.767	151	22.50	0.886	45.00	1.772	10.00	0.394	6.00	0.236	19.51	0.768	12.00	P	Q		
LTML150P 04 LTMR150P 04			425.51	3.767	38	22.50	0.886	45.00	1.772	10.00	0.394	6.00	0.236	5.99	0.236	3.00	P	Q		
LTML150U 02 LTMR150U 02			425.51	3.767	239	22.50	0.886	45.00	1.772	15.00	0.591	10.00	0.394	19.51	0.768	12.00	U	V		
LTML150U 04 LTMR150U 04			425.51	3.767	60	22.50	0.886	45.00	1.772	15.00	0.591	10.00	0.394	5.99	0.236	3.00	R	S		
LTML150X 02 LTMR150X 02			425.51	3.767	328	22.50	0.886	45.00	1.772	20.00	0.787	15.00	0.591	19.51	0.768	12.00	Y	BA		
LTML150X 04 LTMR150X 04			425.51	3.767	82	22.50	0.886	45.00	1.772	20.00	0.787	15.00	0.591	5.99	0.236	3.00	V	X		
LTL063L 02 LTR063L 02			1.60	0.063	621.42	5.500	180	25.40	1.000	50.80	2.000	15.01	0.591	9.91	0.390	14.73	0.580	8.00	T	V
LTL063L 04 LTR063L 04					621.42	5.500		180	25.40	1.000	50.80	2.000	19.48	0.767	13.89	0.547	11.68	0.460	6.00	V
LTL070M 02 LTR070M 02	1.78	0.070	847.39	7.500	180	25.40	1.000	50.80	2.000	15.88	0.625	10.31	0.406	16.26	0.640	8.00	V	X		
LTL070M 04 LTR070M 04			847.39	7.500		180	25.40	1.000	50.80	2.000	20.57	0.810	14.35	0.565	12.70	0.500	6.00	X	Z	
LTL075M 02 LTR075M 02	1.91	0.075	1039.80	9.203	180	25.40	1.000	50.80	2.000	17.07	0.672	10.62	0.418	17.50	0.689	8.00	X	Z		
LTL075M 04 LTR075M 04			1039.80	9.203		180	25.40	1.000	50.80	2.000	19.23	0.757	12.34	0.486	15.54	0.612	7.00	Z	BB	

TORSION SPRINGS



● Left Hand or Right Helix

● Music Wire (Plated) or Stainless Steel (Passivated)

LEE STOCK NUMBER	NOMINAL WIRE DIAMETER		(T) MAXIMUM TORQUE (see footnotes)		DEFLECTION TO MAX. TORQUE DEG (°)	(R) RADIUS		(A) LENGTH OF LEG		OUTSIDE DIAMETER		SUGGESTED MANDREL SIZE		(L) BODY LENGTH APPROX.		TOTAL NO. OF COILS	PRICE LIST			
	MM	IN	N-MM	IN-LB		MM	IN	MM	IN	MM	IN	MM	IN	MM	IN		MM	IN	M	S
LTL078N 02 LTR078N 02	1.98	0.078	1180.69	10.450	180	25.40	1.000	50.80	2.000	17.60	0.693	10.95	0.431	18.19	0.716	8.00	Z	BB		
LTL078N 04 LTR078N 04			1180.69	10.450													180	25.40	1.000	50.80
LTML200S 02 LTMR200S 02	2.00	0.079	978.56	8.663	142	30.00	1.181	60.00	2.362	13.00	0.512	8.00	0.315	26.01	1.024	12.00	R	S		
LTML200S 04 LTMR200S 04			978.56	8.663	35	30.00	1.181	60.00	2.362	13.00	0.512	8.00	0.315	8.00	0.315	3.00	P	Q		
LTML200W 02 LTMR200W 02			978.56	8.663	206	30.00	1.181	60.00	2.362	18.00	0.709	12.00	0.472	26.01	1.024	12.00	X	Z		
LTML200W 04 LTMR200W 04			978.56	8.663	52	30.00	1.181	60.00	2.362	18.00	0.709	12.00	0.472	8.00	0.315	3.00	V	X		
LTML200Y 02 LTMR200Y 02			978.56	8.663	323	30.00	1.181	60.00	2.362	27.00	1.063	20.00	0.787	26.01	1.024	12.00	Z	BB		
LTML200Y 04 LTMR200Y 04			978.56	8.663	81	30.00	1.181	60.00	2.362	27.00	1.063	20.00	0.787	8.00	0.315	3.00	Y	BA		
LTL085N 02 LTR085N 02			2.16	0.085	1453.10	12.861	180	31.75	1.250	63.50	2.500	20.07	0.790	12.70	0.500	19.81	0.780	8.00	BB	BD
LTL085N 04 LTR085N 04					1453.10	12.861													180	31.75
LTL095P 02 LTR095P 02	2.41	0.095	1937.46	17.148	180	38.10	1.500	76.20	3.000	23.37	0.920	15.06	0.593	22.15	0.872	8.00	BD	BF		
LTL095P 04 LTR095P 04			1937.46	17.148													180	38.10	1.500	76.20
LTL105Q 02 LTR105Q 02	2.67	0.105	2372.68	21.000	180	44.45	1.750	88.90	3.500	24.94	0.982	15.47	0.609	26.67	1.050	9.00	BE	BG		
LTL105Q 04 LTR105Q 04			2372.68	21.000													180	44.45	1.750	88.90
LTL115R 02 LTR115R 02	2.92	0.115	3163.58	28.000	180	50.80	2.000	101.60	4.000	26.49	1.043	16.28	0.641	29.21	1.150	9.00	BF	BH		
LTL115R 04 LTR115R 04			3163.58	28.000													180	50.80	2.000	101.60
LTL125S 02 LTR125S 02	3.18	0.125	3615.51	32.000	180	50.80	2.000	101.60	4.000	27.48	1.082	16.92	0.666	38.10	1.500	11.00	BG	BJ		
LTL125S 04 LTR125S 04			3615.51	32.000													180	50.80	2.000	101.60
LTL135T 02 LTR135T 02	3.43	0.135	4519.39	40.000	180	50.80	2.000	101.60	4.000	30.20	1.189	18.67	0.735	41.15	1.620	11.00	BJ	BL		
LTL135T 04 LTR135T 04			4519.39	40.000													180	50.80	2.000	101.60



TORSION SPRINGS

● Left Hand or Right Helix

● Music Wire (Plated) or Stainless Steel (Passivated)

LEE STOCK NUMBER	NOMINAL WIRE DIAMETER		(T) MAXIMUM TORQUE (see footnotes)		DEFLECTION TO MAX. TORQUE DEG (°)	(R) RADIUS		(A) LENGTH OF LEG		OUTSIDE DIAMETER		SUGGESTED MANDREL SIZE		(L) BODY LENGTH APPROX.		TOTAL NO. OF COILS	PRICE LIST			
	MM	IN	N-MM	IN-LB		MM	IN	MM	IN	MM	IN	MM	IN	MM	IN		MM	IN	M	S
LTL016A 20 LTR016A 20	0.41	0.016	12.43	0.110	210	9.53	0.375	19.05	0.750	4.78	0.188	3.18	0.125	2.82	0.111	5.92	M	N		
LTL020B 20 LTR020B 20	0.51	0.020	20.34	0.180	210	12.70	0.500	25.40	1.000	6.96	0.274	4.75	0.187	3.51	0.138	5.92	N	P		
LTL024C 20 LTR024C 20	0.61	0.024	31.64	0.280	210	12.70	0.500	25.40	1.000	9.14	0.360	6.35	0.250	4.22	0.166	5.92	P	Q		
LTL026C 20 LTR026C 20	0.66	0.026	42.93	0.380	210	12.70	0.500	25.40	1.000	9.25	0.364	6.35	0.250	4.57	0.180	5.92	P	Q		
LTL029C 20 LTR029C 20	0.74	0.029	57.62	0.510	210	12.70	0.500	25.40	1.000	9.30	0.366	6.35	0.250	5.84	0.230	6.92	P	Q		
LTL032C 20 LTR032C 20	0.81	0.032	74.57	0.660	210	12.70	0.500	25.40	1.000	9.37	0.369	6.35	0.250	7.24	0.285	7.92	Q	Q		
LTL035C 20 LTR035C 20	0.89	0.035	103.95	0.920	210	15.88	0.625	31.75	1.250	9.53	0.375	6.35	0.250	7.92	0.312	7.92	Q	Q		
LTL038D 20 LTR038D 20	0.97	0.038	134.45	1.190	210	15.88	0.625	31.75	1.250	11.71	0.461	7.92	0.312	7.65	0.301	6.92	Q	R		
LTL040D 20 LTR040D 20	1.02	0.040	164.96	1.460	210	15.88	0.625	31.75	1.250	11.81	0.465	7.92	0.312	8.05	0.317	6.92	Q	R		
LTL042D 20 LTR042D 20	1.07	0.042	170.61	1.510	210	25.40	1.000	50.80	2.000	11.81	0.465	7.92	0.312	9.53	0.375	7.92	S	S		
LTL045D 20 LTR045D 20	1.14	0.045	223.71	1.980	210	25.40	1.000	50.80	2.000	11.96	0.471	7.92	0.312	10.19	0.401	7.92	S	S		
LTL049E 20 LTR049E 20	1.24	0.049	266.64	2.360	210	25.40	1.000	50.80	2.000	14.12	0.556	9.53	0.375	11.10	0.437	7.92	S	T		
LTL055E 20 LTR055E 20	1.40	0.055	373.98	3.310	210	25.40	1.000	50.80	2.000	14.33	0.564	9.53	0.375	13.84	0.545	8.92	T	T		
LTL059E 20 LTR059E 20	1.50	0.059	444.03	3.930	210	25.40	1.000	50.80	2.000	14.45	0.569	9.53	0.375	16.36	0.644	9.92	V	W		
LTL063E 20 LTR063E 20	1.59	0.063	572.83	5.070	210	25.40	1.000	50.80	2.000	14.68	0.578	9.53	0.375	17.32	0.682	9.92	V	W		
LTL072F 20 LTR072F 20	1.83	0.072	836.09	7.400	210	25.40	1.000	50.80	2.000	19.05	0.750	12.70	0.500	18.14	0.714	8.92	X	Y		
LTL080F 20 LTR080F 20	2.03	0.080	1182.95	10.470	210	31.75	1.250	63.50	2.500	19.41	0.764	12.70	0.500	20.14	0.793	8.92	X	Y		
LTL085G 20 LTR085G 20	2.16	0.085	1307.23	11.570	210	31.75	1.250	63.50	2.500	23.55	0.927	15.88	0.625	21.41	0.843	8.92	Y	Z		
LTL092G 20 LTR092G 20	2.32	0.092	1594.22	14.110	210	38.10	1.500	76.20	3.000	23.77	0.936	15.88	0.625	25.37	0.999	9.92	Y	Z		
LTL095G 20 LTR095G 20	2.41	0.095	1881.20	16.650	210	38.10	1.500	76.20	3.000	23.98	0.944	15.88	0.625	26.34	1.037	9.92	Y	Z		
LTL105H 20 LTR105H 20	2.67	0.105	2512.78	22.240	210	44.45	1.750	88.90	3.500	28.40	1.118	19.05	0.750	26.44	1.041	8.92	Y	Z		
LTL112H 20 LTR112H 20	2.84	0.112	2901.45	25.680	210	50.80	2.000	101.60	4.000	28.60	1.126	19.05	0.750	31.06	1.223	9.92	Z	Z		
LTL125H 20 LTR125H 20	3.18	0.125	4052.77	35.870	210	50.80	2.000	101.60	4.000	29.16	1.148	19.05	0.750	37.85	1.490	10.92	Z	BA		
LTL135H 20 LTR135H 20	3.43	0.135	4642.55	41.090	210	50.80	2.000	101.60	4.000	29.46	1.160	19.05	0.750	47.73	1.879	12.92	BA	BA		

TORSION SPRINGS



● Left Hand or Right Helix

● Music Wire (Plated) or Stainless Steel (Passivated)

LEE STOCK NUMBER	NOMINAL WIRE DIAMETER		(T) MAXIMUM TORQUE (see footnotes)		DEFLECTION TO MAX. TORQUE DEG (°)	(R) RADIUS		(A) LENGTH OF LEG		OUTSIDE DIAMETER		SUGGESTED MANDREL SIZE		(L) BODY LENGTH APPROX.		TOTAL NO. OF COILS	PRICE LIST			
	MM	IN	N-MM	IN-LB		MM	IN	MM	IN	MM	IN	MM	IN	MM	IN		M	S		
	LTL012A 03 LTR012A 03	0.30	0.012	5.65	0.050	270	4.76	0.188	9.53	0.375	2.62	0.103	1.57	0.062	3.53	0.139	9.75	L	M	
LTL012A 05 LTR012A 05	5.65			0.050	270	6.35	0.250	12.70	0.500	4.34	0.171	2.77	0.109	2.18	0.086	5.75	L	M		
LTL014A 03 LTR014A 03	0.36	0.014	8.47	0.075	270	6.35	0.250	12.70	0.500	3.15	0.124	1.57	0.062	3.96	0.156	9.75	L	M		
LTL014A 05 LTR014A 05			8.47	0.075	270	9.53	0.375	19.05	0.750	5.11	0.201	2.77	0.109	2.54	0.100	5.75	L	M		
LTL015B 03 LTR015B 03	0.38	0.015	11.30	0.100	270	6.35	0.250	12.70	0.500	3.18	0.125	1.98	0.078	4.39	0.173	9.75	L	M		
LTL015B 05 LTR015B 05			11.30	0.100	270	9.53	0.375	19.05	0.750	5.08	0.200	2.77	0.109	2.72	0.107	5.75	L	M		
LTML040A 03 LTMR040A 03	0.40	0.016	9.97	0.088	140	8.00	0.315	16.00	0.630	2.80	0.110	1.50	0.059	3.99	0.157	8.75	L	M		
LTML040A 05 LTMR040A 05			9.97	0.088	44	8.00	0.315	16.00	0.630	2.80	0.110	1.50	0.059	1.60	0.063	2.75	L	M		
LTML040C 03 LTMR040C 03			9.97	0.088	198	8.00	0.315	16.00	0.630	3.80	0.150	2.50	0.098	3.99	0.157	8.75	L	M		
LTML040C 05 LTMR040C 05			9.97	0.088	62	8.00	0.315	16.00	0.630	3.80	0.150	2.50	0.098	1.60	0.063	2.75	L	M		
LTML040G 03 LTMR040G 03			9.97	0.088	315	8.00	0.315	16.00	0.630	5.80	0.228	4.00	0.157	3.99	0.157	8.75	L	M		
LTML040G 05 LTMR040G 05			9.97	0.088	99	8.00	0.315	16.00	0.630	5.80	0.228	4.00	0.157	1.60	0.063	2.75	L	M		
LTL017C 03 LTR017C 03			0.43	0.017	14.12	0.125	270	6.35	0.250	12.70	0.500	4.06	0.160	2.36	0.093	4.78	0.188	9.75	L	M
LTL017C 05 LTR017C 05					14.12	0.125	270	9.53	0.375	19.05	0.750	6.58	0.259	4.45	0.175	3.05	0.120	5.75	L	M
LTL018C 03 LTR018C 03	0.46	0.018	16.95	0.150	270	6.35	0.250	12.70	0.500	4.06	0.160	2.77	0.109	5.79	0.228	10.75	L	M		
LTL018C 05 LTR018C 05			16.95	0.150	270	9.53	0.375	19.05	0.750	6.25	0.246	3.96	0.156	3.81	0.150	6.75	L	M		
LTML050B 03 LTMR050B 03	0.50	0.020	17.90	0.159	132	10.00	0.394	20.00	0.787	3.50	0.138	2.00	0.079	5.00	0.197	8.75	L	M		
LTML050B 05 LTMR050B 05			17.90	0.159	42	10.00	0.394	20.00	0.787	3.50	0.138	2.00	0.079	2.01	0.079	2.75	L	M		
LTML050E 03 LTMR050E 03			17.90	0.159	176	10.00	0.394	20.00	0.787	4.50	0.177	3.00	0.118	5.00	0.197	8.75	L	M		
LTML050E 05 LTMR050E 05			17.90	0.159	55	10.00	0.394	20.00	0.787	4.50	0.177	3.00	0.118	2.01	0.079	2.75	L	M		
LTML050J 03 LTMR050J 03			17.90	0.159	286	10.00	0.394	20.00	0.787	7.00	0.276	5.00	0.197	5.00	0.197	8.75	M	P		
LTML050J 05 LTMR050J 05			17.90	0.159	90	10.00	0.394	20.00	0.787	7.00	0.276	5.00	0.197	2.01	0.079	2.75	M	N		
LTL020D 03 LTR020D 03	0.51	0.020	22.60	0.200	270	9.53	0.375	19.05	0.750	4.45	0.175	2.67	0.105	6.10	0.240	10.75	L	M		
LTL020D 05 LTR020D 05			22.60	0.200	270	12.70	0.500	25.40	1.000	6.81	0.268	4.75	0.187	4.06	0.160	6.75	L	M		
LTL021D 03 LTR021D 03	0.53	0.021	28.25	0.250	270	9.53	0.375	19.05	0.750	4.70	0.185	2.77	0.109	6.76	0.266	10.75	L	M		
LTL021D 05 LTR021D 05			28.25	0.250	270	12.70	0.500	25.40	1.000	6.25	0.246	3.76	0.148	4.95	0.195	7.75	L	M		
LTL023D 03 LTR023D 03	0.58	0.023	37.28	0.330	270	9.53	0.375	19.05	0.750	4.75	0.187	2.77	0.109	7.11	0.280	10.75	L	M		
LTL023D 05 LTR023D 05			37.28	0.330	270	12.70	0.500	25.40	1.000	6.38	0.251	4.11	0.162	5.33	0.210	7.75	L	M		



TORSION SPRINGS

● Left Hand or Right Helix

● Music Wire (Plated) or Stainless Steel (Passivated)

LEE STOCK NUMBER	NOMINAL WIRE DIAMETER		(T) MAXIMUM TORQUE (see footnotes)		DEFLECTION TO MAX. TORQUE DEG (°)	(R) RADIUS		(A) LENGTH OF LEG		OUTSIDE DIAMETER		SUGGESTED MANDREL SIZE		(L) BODY LENGTH APPROX.		TOTAL NO. OF COILS	PRICE LIST	
	MM	IN	N-MM	IN-LB		MM	IN	MM	IN	MM	IN	MM	IN	MM	IN		Music Wire	302 Stainless
																	M	S
LTML060D 03 LTMR060D 03	0.60	0.024	31.94	0.283	130	11.00	0.433	22.00	0.866	4.20	0.165	2.50	0.098	5.99	0.236	8.75	L	M
LTML060D 05 LTMR060D 05			31.94	0.283	41	11.00	0.433	22.00	0.866	4.20	0.165	2.50	0.098	2.39	0.094	2.75	L	M
LTML060H 03 LTMR060H 03	0.60	0.024	31.94	0.283	203	11.00	0.433	22.00	0.866	6.20	0.244	4.00	0.157	5.99	0.236	8.75	L	M
LTML060H 05 LTMR060H 05			31.94	0.283	64	11.00	0.433	22.00	0.866	6.20	0.244	4.00	0.157	2.39	0.094	2.75	L	M
LTML060L 03 LTMR060L 03	0.60	0.024	31.94	0.283	275	11.00	0.433	22.00	0.866	8.20	0.323	6.00	0.236	5.99	0.236	8.75	N	P
LTML060L 05 LTMR060L 05			31.94	0.283	87	11.00	0.433	22.00	0.866	8.20	0.323	6.00	0.236	2.39	0.094	2.75	M	N
LTL025E 03 LTR025E 03	0.64	0.025	47.45	0.420	270	9.53	0.375	19.05	0.750	5.59	0.220	3.56	0.140	7.72	0.304	10.75	L	M
LTL025E 05 LTR025E 05			47.45	0.420	270	12.70	0.500	25.40	1.000	8.66	0.341	5.54	0.218	5.23	0.206	6.75	L	M
LTL028E 03 LTR028E 03	0.71	0.028	62.14	0.550	270	12.70	0.500	25.40	1.000	6.22	0.245	3.96	0.156	8.64	0.340	10.75	M	N
LTL028E 05 LTR028E 05			62.14	0.550	270	12.70	0.500	25.40	1.000	8.36	0.329	5.72	0.225	6.48	0.255	7.75	M	P
LTML075F 03 LTMR075F 03	0.75	0.030	58.84	0.521	121	12.50	0.492	25.00	0.984	5.00	0.197	3.00	0.118	7.49	0.295	8.75	L	M
LTML075F 05 LTMR075F 05			58.84	0.521	38	12.50	0.492	25.00	0.984	5.00	0.197	3.00	0.118	3.00	0.118	2.75	L	M
LTML075K 03 LTMR075K 03	0.75	0.030	58.84	0.521	193	12.50	0.492	25.00	0.984	7.50	0.295	5.00	0.197	7.49	0.295	8.75	N	P
LTML075K 05 LTMR075K 05			58.84	0.521	61	12.50	0.492	25.00	0.984	7.50	0.295	5.00	0.197	3.00	0.118	2.75	M	N
LTML075Q 03 LTMR075Q 03	0.75	0.030	58.84	0.521	279	12.50	0.492	25.00	0.984	10.50	0.413	8.00	0.315	7.49	0.295	8.75	P	Q
LTML075Q 05 LTMR075Q 05			58.84	0.521	88	12.50	0.492	25.00	0.984	10.50	0.413	8.00	0.315	3.00	0.118	2.75	P	Q
LTL030F 03 LTR030F 03	0.76	0.030	76.83	0.680	270	12.70	0.500	25.40	1.000	6.88	0.271	4.37	0.172	9.27	0.365	10.75	M	N
LTL030F 05 LTR030F 05			76.83	0.680	270	12.70	0.500	25.40	1.000	9.58	0.377	6.35	0.250	7.11	0.280	7.75	M	P
LTL032F 03 LTR032F 03	0.81	0.032	98.86	0.875	270	12.70	0.500	25.40	1.000	6.71	0.264	4.11	0.162	9.78	0.385	10.75	M	N
LTL032F 05 LTR032F 05			98.86	0.875	270	12.70	0.500	25.40	1.000	8.99	0.354	6.10	0.240	7.37	0.290	7.75	M	P
LTL035G 03 LTR035G 03	0.89	0.035	120.89	1.070	270	15.88	0.625	31.75	1.250	7.92	0.312	4.75	0.187	10.80	0.425	10.75	M	N
LTL035G 05 LTR035G 05			120.89	1.070	270	15.88	0.625	31.75	1.250	11.07	0.436	7.14	0.281	8.00	0.315	7.75	N	P
LTL038G 03 LTR038G 03	0.97	0.038	144.62	1.280	270	15.88	0.625	31.75	1.250	9.02	0.355	5.84	0.230	11.56	0.455	10.75	N	P
LTL038G 05 LTR038G 05			144.62	1.280	270	15.88	0.625	31.75	1.250	12.12	0.477	8.38	0.330	8.69	0.342	7.75	N	P
LTML100J 03 LTMR100J 03	1.00	0.039	136.12	1.205	125	17.50	0.689	35.00	1.378	7.00	0.276	4.00	0.157	10.01	0.394	8.75	M	N
LTML100J 05 LTMR100J 05			136.12	1.205	39	17.50	0.689	35.00	1.378	7.00	0.276	4.00	0.157	3.99	0.157	2.75	M	N
LTML100N 03 LTMR100N 03	1.00	0.039	136.12	1.205	167	17.50	0.689	35.00	1.378	9.00	0.354	6.00	0.236	10.01	0.394	8.75	M	N
LTML100N 05 LTMR100N 05			136.12	1.205	52	17.50	0.689	35.00	1.378	9.00	0.354	6.00	0.236	3.99	0.157	2.75	M	N
LTML100T 03 LTMR100T 03	1.00	0.039	136.12	1.205	271	17.50	0.689	35.00	1.378	14.00	0.551	10.00	0.394	10.01	0.394	8.75	R	S
LTML100T 05 LTMR100T 05			136.12	1.205	85	17.50	0.689	35.00	1.378	14.00	0.551	10.00	0.394	3.99	0.157	2.75	P	Q

TORSION SPRINGS



● Left Hand or Right Helix

● Music Wire (Plated) or Stainless Steel (Passivated)

LEE STOCK NUMBER	NOMINAL WIRE DIAMETER		(T) MAXIMUM TORQUE (see footnotes)		DEFLECTION TO MAX. TORQUE DEG (°)	(R) RADIUS		(A) LENGTH OF LEG		OUTSIDE DIAMETER		SUGGESTED MANDREL SIZE		(L) BODY LENGTH APPROX.		TOTAL NO. OF COILS	PRICE LIST			
	MM	IN	N-MM	IN-LB		MM	IN	MM	IN	MM	IN	MM	IN	MM	IN		M	S		
																			Music Wire	302 Stainless
LTL040H 03 LTR040H 03	1.02	0.040	169.48	1.500	270	15.88	0.625	31.75	1.250	9.12	0.359	5.54	0.218	13.34	0.525	11.75	S	T		
LTL040H 05 LTR040H 05			169.48	1.500		270	25.40	1.000	50.80	2.000	13.00	0.512	8.71	0.343	9.14	0.360	7.75	N	P	
LTL045H 03 LTR045H 03	1.14	0.045	242.92	2.150	270	15.88	0.625	31.75	1.250	9.70	0.382	6.10	0.240	14.86	0.585	11.75	N	P		
LTL045H 05 LTR045H 05			242.92	2.150		270	25.40	1.000	50.80	2.000	14.12	0.556	9.53	0.375	10.29	0.405	7.75	N	P	
LTL048J 03 LTR048J 03	1.22	0.048	310.71	2.750	270	15.88	0.625	31.75	1.250	10.59	0.417	6.35	0.250	16.00	0.630	11.75	Q	R		
LTL048J 05 LTR048J 05			310.71	2.750		270	25.40	1.000	50.80	2.000	15.27	0.601	10.31	0.406	11.05	0.435	7.75	Q	R	
LTML125M 03 LTMR125M 03	1.25	0.049	255.09	2.258	117	20.00	0.787	40.00	1.575	8.50	0.335	5.00	0.197	12.50	0.492	8.75	N	P		
LTML125M 05 LTMR125M 05			255.09	2.258	37	20.00	0.787	40.00	1.575	8.50	0.335	5.00	0.197	5.00	0.197	2.75	L	M		
LTML125R 03 LTMR125R 03			255.09	2.258	165	20.00	0.787	40.00	1.575	11.50	0.453	8.00	0.315	12.50	0.492	8.75	P	Q		
LTML125R 05 LTMR125R 05			255.09	2.258	52	20.00	0.787	40.00	1.575	11.50	0.453	8.00	0.315	5.00	0.197	2.75	P	R		
LTML125V 03 LTMR125V 03			255.09	2.258	245	20.00	0.787	40.00	1.575	16.50	0.650	12.00	0.472	12.50	0.492	8.75	S	T		
LTML125V 05 LTMR125V 05			255.09	2.258	77	20.00	0.787	40.00	1.575	16.50	0.650	12.00	0.472	5.00	0.197	2.75	P	Q		
LTL051J 03 LTR051J 03			1.30	0.051	350.25	3.100	270	25.40	1.000	50.80	2.000	11.15	0.439	7.11	0.280	16.76	0.660	11.75	Q	R
LTL051J 05 LTR051J 05					350.25	3.100		270	25.40	1.000	50.80	2.000	14.50	0.571	9.91	0.390	12.95	0.510	8.75	Q
LTL054K 03 LTR054K 03			1.37	0.054	395.45	3.500	270	25.40	1.000	50.80	2.000	13.06	0.514	8.76	0.345	17.78	0.700	11.75	R	S
LTL054K 05 LTR054K 05					395.45	3.500		270	25.40	1.000	50.80	2.000	16.87	0.664	12.07	0.475	13.72	0.540	8.75	R
LTL059K 03 LTR059K 03	1.50	0.059	508.43	4.500	270	25.40	1.000	50.80	2.000	13.64	0.537	8.89	0.350	19.43	0.765	11.75	T	U		
LTL059K 05 LTR059K 05			508.43	4.500		270	25.40	1.000	50.80	2.000	17.75	0.699	12.32	0.485	14.86	0.585	8.75	T	V	
LTML150P 03 LTMR150P 03			425.51	3.767	110	22.50	0.886	45.00	1.772	10.00	0.394	6.00	0.236	15.01	0.591	8.75	P	Q		
LTML150P 05 LTMR150P 05			425.51	3.767	35	22.50	0.886	45.00	1.772	10.00	0.394	6.00	0.236	5.99	0.236	2.75	M	N		
LTML150U 03 LTMR150U 03			425.51	3.767	175	22.50	0.886	45.00	1.772	15.00	0.591	10.00	0.394	15.01	0.591	8.75	R	S		
LTML150U 05 LTMR150U 05			425.51	3.767	55	22.50	0.886	45.00	1.772	15.00	0.591	10.00	0.394	5.99	0.236	2.75	P	Q		
LTML150X 03 LTMR150X 03			425.51	3.767	239	22.50	0.886	45.00	1.772	20.00	0.787	15.00	0.591	15.01	0.591	8.75	V	X		
LTML150X 05 LTMR150X 05			425.51	3.767	75	22.50	0.886	45.00	1.772	20.00	0.787	15.00	0.591	5.99	0.236	2.75	U	W		
LTL063L 03 LTR063L 03			1.60	0.063	621.42	5.500	270	25.40	1.000	50.80	2.000	15.24	0.600	10.31	0.406	20.83	0.820	11.75	T	V
LTL063L 05 LTR063L 05					621.42	5.500		270	25.40	1.000	50.80	2.000	19.91	0.784	14.27	0.562	16.00	0.630	8.75	V
LTL070M 03 LTR070M 03	1.78	0.070	847.39	7.500	270	25.40	1.000	50.80	2.000	16.23	0.639	11.11	0.438	22.68	0.893	11.75	V	X		
LTL070M 05 LTR070M 05			847.39	7.500		270	25.40	1.000	50.80	2.000	20.98	0.826	15.48	0.609	17.35	0.683	8.75	X	Z	
LTL075M 03 LTR075M 03	1.91	0.075	1039.80	9.203	270	25.40	1.000	50.80	2.000	17.40	0.685	12.30	0.484	24.28	0.956	11.75	X	Z		
LTL075M 05 LTR075M 05			1039.80	9.203		270	25.40	1.000	50.80	2.000	20.57	0.810	13.39	0.527	20.88	0.822	9.75	Z	BB	



TORSION SPRINGS

● Left Hand or Right Helix

● Music Wire (Plated) or Stainless Steel (Passivated)

LEE STOCK NUMBER	NOMINAL WIRE DIAMETER		(T) MAXIMUM TORQUE (see footnotes)		DEFLECTION TO MAX. TORQUE DEG (°)	(R) RADIUS		(A) LENGTH OF LEG		OUTSIDE DIAMETER		SUGGESTED MANDREL SIZE		(L) BODY LENGTH APPROX.		TOTAL NO. OF COILS	PRICE LIST			
	MM	IN	N-MM	IN-LB		MM	IN	MM	IN	MM	IN	MM	IN	MM	IN		Music Wire	302 Stainless		
																	M	S		
LTL078N 03 LTR078N 03	1.98	0.078	1180.69	10.450	270	25.40	1.000	50.80	2.000	17.93	0.706	12.30	0.484	25.27	0.995	11.75	Z	BB		
LTL078N 05 LTR078N 05			1180.69	10.450													270	25.40	1.000	50.80
LTML200S 03 LTMR200S 03	2.00	0.079	978.56	8.663	103	30.00	1.181	60.00	2.362	13.00	0.512	8.00	0.315	19.99	0.787	8.75	Q	R		
LTML200S 05 LTMR200S 05			978.56	8.663	33	30.00	1.181	60.00	2.362	13.00	0.512	8.00	0.315	8.00	0.315	2.75	P	Q		
LTML200W 03 LTMR200W 03			978.56	8.663	151	30.00	1.181	60.00	2.362	18.00	0.709	12.00	0.472	19.99	0.787	8.75	V	X		
LTML200W 05 LTMR200W 05			978.56	8.663	47	30.00	1.181	60.00	2.362	18.00	0.709	12.00	0.472	8.00	0.315	2.75	V	X		
LTML200Y 03 LTMR200Y 03			978.56	8.663	235	30.00	1.181	60.00	2.362	27.00	1.063	20.00	0.787	19.99	0.787	8.75	X	Z		
LTML200Y 05 LTMR200Y 05			978.56	8.663	74	30.00	1.181	60.00	2.362	27.00	1.063	20.00	0.787	8.00	0.315	2.75	W	Y		
LTL085N 03 LTR085N 03			2.16	0.085	1453.10	12.861	270	31.75	1.250	63.50	2.500	20.45	0.805	14.68	0.578	27.53	1.084	11.75	BB	BD
LTL085N 05 LTR085N 05					1453.10	12.861													270	31.75
LTL095P 03 LTR095P 03	2.41	0.095	1937.46	17.148	270	38.10	1.500	76.20	3.000	23.80	0.937	17.07	0.672	30.76	1.211	11.75	BD	BF		
LTL095P 05 LTR095P 05			1937.46	17.148													270	38.10	1.500	76.20
LTL105Q 03 LTR105Q 03	2.67	0.105	2372.68	21.000	270	44.45	1.750	88.90	3.500	27.69	1.090	17.86	0.703	34.01	1.339	11.75	BE	BG		
LTL105Q 05 LTR105Q 05			2372.68	21.000													270	44.45	1.750	88.90
LTL115R 03 LTR115R 03	2.92	0.115	3163.58	28.000	270	50.80	2.000	101.60	4.000	27.58	1.086	17.48	0.688	43.08	1.696	13.75	BF	BH		
LTL115R 05 LTR115R 05			3163.58	28.000													270	50.80	2.000	101.60
LTL125S 03 LTR125S 03	3.18	0.125	3615.51	32.000	270	50.80	2.000	101.60	4.000	30.20	1.189	19.08	0.751	50.00	1.969	14.75	BG	BJ		
LTL125S 05 LTR125S 05			3615.51	32.000													270	50.80	2.000	101.60
LTL135T 03 LTR135T 03	3.43	0.135	4519.39	40.000	270	50.80	2.000	101.60	4.000	33.05	1.301	20.96	0.825	54.01	2.126	14.75	BJ	BL		
LTL135T 05 LTR135T 05			4519.39	40.000													270	50.80	2.000	101.60

TORSION SPRINGS

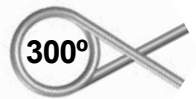

● Left Hand or Right Helix

● Music Wire (Plated) or Stainless Steel (Passivated)

LEE STOCK NUMBER	NOMINAL WIRE DIAMETER		(T) MAXIMUM TORQUE (see footnotes)		DEFLECTION TO MAX. TORQUE DEG (°)	(R) RADIUS		(A) LENGTH OF LEG		OUTSIDE DIAMETER		SUGGESTED MANDREL SIZE		(L) BODY LENGTH APPROX.		TOTAL NO. OF COILS	PRICE LIST	
	MM	IN	N-MM	IN-LB		MM	IN	MM	IN	MM	IN	MM	IN	MM	IN		Music Wire	302 Stainless
																	M	S
LTL016A 30 LTR016A 30	0.41	0.016	12.43	0.110	300	9.53	0.375	19.05	0.750	4.78	0.188	3.18	0.125	3.94	0.155	8.67	M	N
LTL020B 30 LTR020B 30	0.51	0.020	20.34	0.180	300	12.70	0.500	25.40	1.000	6.93	0.273	4.75	0.187	4.90	0.193	8.67	M	N
LTL024C 30 LTR024C 30	0.61	0.024	31.64	0.280	300	12.70	0.500	25.40	1.000	9.12	0.359	6.35	0.250	5.89	0.232	8.67	N	P
LTL026C 30 LTR026C 30	0.66	0.026	42.93	0.380	300	12.70	0.500	25.40	1.000	9.25	0.364	6.35	0.250	6.38	0.251	8.67	N	P
LTL029C 30 LTR029C 30	0.74	0.029	59.88	0.530	300	12.70	0.500	25.40	1.000	9.32	0.367	6.35	0.250	7.85	0.309	9.67	N	P
LTL032C 30 LTR032C 30	0.81	0.032	79.09	0.700	300	12.70	0.500	25.40	1.000	9.42	0.371	6.35	0.250	9.47	0.373	10.67	P	Q
LTL035C 30 LTR035C 30	0.89	0.035	111.85	0.990	300	15.88	0.625	31.75	1.250	9.58	0.377	6.35	0.250	10.36	0.408	10.67	Q	Q
LTL038D 30 LTR038D 30	0.97	0.038	140.10	1.240	300	15.88	0.625	31.75	1.250	11.73	0.462	7.92	0.312	10.29	0.405	9.67	Q	Q
LTL040D 30 LTR040D 30	1.02	0.040	154.79	1.370	300	15.88	0.625	31.75	1.250	11.76	0.463	7.92	0.312	11.86	0.467	10.67	Q	Q
LTL042D 30 LTR042D 30	1.07	0.042	169.48	1.500	300	25.40	1.000	50.80	2.000	11.79	0.464	7.92	0.312	13.51	0.532	11.67	R	S
LTL045D 30 LTR045D 30	1.14	0.045	221.45	1.960	300	25.40	1.000	50.80	2.000	11.94	0.470	7.92	0.312	14.48	0.570	11.67	R	S
LTL049E 30 LTR049E 30	1.24	0.049	286.98	2.540	300	25.40	1.000	50.80	2.000	14.17	0.558	9.53	0.375	14.53	0.572	10.67	S	S
LTL055E 30 LTR055E 30	1.40	0.055	381.89	3.380	300	25.40	1.000	50.80	2.000	14.33	0.564	9.53	0.375	19.10	0.752	12.67	U	V
LTL059E 30 LTR059E 30	1.50	0.059	465.50	4.120	300	25.40	1.000	50.80	2.000	14.48	0.570	9.53	0.375	21.97	0.865	13.67	V	W
LTL063E 30 LTR063E 30	1.59	0.063	561.53	4.970	300	25.40	1.000	50.80	2.000	14.66	0.577	9.53	0.375	23.29	0.917	13.67	V	W
LTL072F 30 LTR072F 30	1.83	0.072	849.65	7.520	300	25.40	1.000	50.80	2.000	19.05	0.750	12.70	0.500	23.16	0.912	11.67	W	W
LTL080F 30 LTR080F 30	2.03	0.080	1156.96	10.240	300	31.75	1.250	63.50	2.500	19.38	0.763	12.70	0.500	29.79	1.173	13.67	X	Y
LTL085G 30 LTR085G 30	2.16	0.085	1328.70	11.760	300	31.75	1.250	63.50	2.500	23.55	0.927	15.88	0.625	29.51	1.162	12.67	Y	Y
LTL092G 30 LTR092G 30	2.32	0.092	1671.05	14.790	300	38.10	1.500	76.20	3.000	23.83	0.938	15.88	0.625	31.78	1.251	12.67	Y	Y
LTL095G 30 LTR095G 30	2.41	0.095	1840.52	16.290	300	38.10	1.500	76.20	3.000	23.95	0.943	15.88	0.625	35.38	1.393	13.67	Z	Z
LTL105H 30 LTR105H 30	2.67	0.105	2377.20	21.040	300	44.45	1.750	88.90	3.500	28.30	1.114	19.05	0.750	39.12	1.540	13.67	BA	BA
LTL112H 30 LTR112H 30	2.84	0.112	3043.81	26.940	300	50.80	2.000	101.60	4.000	28.65	1.128	19.05	0.750	41.73	1.643	13.67	BA	BA
LTL125H 30 LTR125H 30	3.18	0.125	3843.74	34.020	300	50.80	2.000	101.60	4.000	29.08	1.145	19.05	0.750	56.08	2.208	16.67	BA	BB
LTL135H 30 LTR135H 30	3.43	0.135	4891.11	43.290	300	50.80	2.000	101.60	4.000	29.51	1.162	19.05	0.750	64.01	2.520	17.67	BB	BC

TORSION SPRINGS

● Left Hand or Right Helix

● Music Wire (Plated) or Stainless Steel (Passivated)

LEE STOCK NUMBER	NOMINAL WIRE DIAMETER		(T) MAXIMUM TORQUE (see footnotes)		DEFLECTION TO MAX. TORQUE DEG (°)	(R) RADIUS		(A) LENGTH OF LEG		OUTSIDE DIAMETER		SUGGESTED MANDREL SIZE		(L) BODY LENGTH APPROX.		TOTAL NO. OF COILS	PRICE LIST			
	MM	IN	N-MM	IN-LB		MM	IN	MM	IN	MM	IN	MM	IN	MM	IN		Music Wire	302 Stainless		
																	M	S		
LTL012A 06 LTR012A 06	0.30	0.012	5.65	0.050	360	6.35	0.250	12.70	0.500	4.42	0.174	2.77	0.109	2.84	0.112	7.50	L	M		
LTL012A 08 LTR012A 08			5.65	0.050		360	9.53	0.375	19.05	0.750	5.61	0.221	3.96	0.156	1.98	0.078	5.50	L	M	
LTL014A 06 LTR014A 06	0.36	0.014	8.47	0.075	360	9.53	0.375	19.05	0.750	5.18	0.204	2.77	0.109	3.15	0.124	7.50	L	M		
LTL014A 08 LTR014A 08			8.47	0.075		360	9.53	0.375	19.05	0.750	6.93	0.273	4.78	0.188	2.31	0.091	5.50	L	M	
LTL015B 06 LTR015B 06	0.38	0.015	11.30	0.100	360	9.53	0.375	19.05	0.750	5.28	0.208	2.77	0.109	3.35	0.132	7.50	L	M		
LTL015B 08 LTR015B 08			11.30	0.100		360	12.70	0.500	25.40	1.000	6.88	0.271	4.78	0.188	2.49	0.098	5.50	L	M	
LTML040A 06 LTMR040A 06	0.40	0.016	9.97	0.088	104	8.00	0.315	16.00	0.630	2.80	0.110	1.50	0.059	2.79	0.110	6.50	L	M		
LTML040A 08 LTMR040A 08			9.97	0.088	40	8.00	0.315	16.00	0.630	2.80	0.110	1.50	0.059	1.19	0.047	2.50	L	M		
LTML040C 06 LTMR040C 06			9.97	0.088	147	8.00	0.315	16.00	0.630	3.80	0.150	2.50	0.098	2.79	0.110	6.50	L	M		
LTML040C 08 LTMR040C 08			9.97	0.088	57	8.00	0.315	16.00	0.630	3.80	0.150	2.50	0.098	1.19	0.047	2.50	L	M		
LTML040G 06 LTMR040G 06			9.97	0.088	234	8.00	0.315	16.00	0.630	5.80	0.228	4.00	0.157	2.79	0.110	6.50	L	M		
LTML040G 08 LTMR040G 08			9.97	0.088	90	8.00	0.315	16.00	0.630	5.80	0.228	4.00	0.157	1.19	0.047	2.50	L	M		
LTL017C 06 LTR017C 06			0.43	0.017	14.12	0.125	360	9.53	0.375	19.05	0.750	5.97	0.235	3.96	0.156	4.24	0.167	8.50	L	M
LTL017C 08 LTR017C 08					14.12	0.125		360	12.70	0.500	25.40	1.000	7.70	0.303	5.56	0.219	3.25	0.128	6.50	L
LTL018C 06 LTR018C 06	0.46	0.018	16.95	0.150	360	9.53	0.375	19.05	0.750	5.94	0.234	3.96	0.156	5.08	0.200	9.50	L	M		
LTL018C 08 LTR018C 08			16.95	0.150		360	12.70	0.500	25.40	1.000	9.42	0.371	6.76	0.266	2.97	0.117	5.50	M	N	
LTML050B 06 LTMR050B 06	0.50	0.020	17.90	0.159	98	10.00	0.394	20.00	0.787	3.50	0.138	2.00	0.079	3.51	0.138	6.50	L	M		
LTML050B 08 LTMR050B 08			17.90	0.159	38	10.00	0.394	20.00	0.787	3.50	0.138	2.00	0.079	1.50	0.059	2.50	L	M		
LTML050E 06 LTMR050E 06			17.90	0.159	131	10.00	0.394	20.00	0.787	4.50	0.177	3.00	0.118	3.51	0.138	6.50	L	M		
LTML050E 08 LTMR050E 08			17.90	0.159	50	10.00	0.394	20.00	0.787	4.50	0.177	3.00	0.118	1.50	0.059	2.50	L	M		
LTML050J 06 LTMR050J 06			17.90	0.159	213	10.00	0.394	20.00	0.787	7.00	0.276	5.00	0.197	3.51	0.138	6.50	M	N		
LTML050J 08 LTMR050J 08			17.90	0.159	82	10.00	0.394	20.00	0.787	7.00	0.276	5.00	0.197	1.50	0.059	2.50	M	N		
LTL020D 06 LTR020D 06	0.51	0.020	22.60	0.200	360	12.70	0.500	25.40	1.000	6.45	0.254	4.37	0.172	5.46	0.215	9.50	L	M		
LTL020D 08 LTR020D 08			22.60	0.200		360	15.88	0.625	31.75	1.250	10.77	0.424	7.92	0.312	3.30	0.130	5.50	M	N	
LTL021D 06 LTR021D 06	0.53	0.021	28.25	0.250	360	12.70	0.500	25.40	1.000	6.91	0.272	4.75	0.187	5.84	0.230	9.50	L	M		
LTL021D 08 LTR021D 08			28.25	0.250		360	12.70	0.500	25.40	1.000	10.52	0.414	7.54	0.297	3.45	0.136	5.50	L	N	
LTL023D 06 LTR023D 06	0.58	0.023	37.28	0.330	360	12.70	0.500	25.40	1.000	6.88	0.271	4.57	0.180	6.35	0.250	9.50	L	M		
LTL023D 08 LTR023D 08			37.28	0.330		360	15.88	0.625	31.75	1.250	11.46	0.451	8.33	0.328	3.81	0.150	5.50	M	N	

TORSION SPRINGS

360°

● Left Hand or Right Helix

● Music Wire (Plated) or Stainless Steel (Passivated)

LEE STOCK NUMBER	NOMINAL WIRE DIAMETER		(T) MAXIMUM TORQUE (see footnotes)		DEFLECTION TO MAX. TORQUE DEG (°)	(R) RADIUS		(A) LENGTH OF LEG		OUTSIDE DIAMETER		SUGGESTED MANDREL SIZE		(L) BODY LENGTH APPROX.		TOTAL NO. OF COILS	PRICE LIST			
	MM	IN	N-MM	IN-LB		MM	IN	MM	IN	MM	IN	MM	IN	MM	IN		M	S		
																			Music Wire	302 Stainless
LTML060D 06 LTMR060D 06	0.60	0.024	31.94	0.283	97	11.00	0.433	22.00	0.866	4.20	0.165	2.50	0.098	4.19	0.165	6.50	L	M		
LTML060D 08 LTMR060D 08			31.94	0.283	37	11.00	0.433	22.00	0.866	4.20	0.165	2.50	0.098	1.80	0.071	2.50	L	M		
LTML060H 06 LTMR060H 06			31.94	0.283	151	11.00	0.433	22.00	0.866	6.20	0.244	4.00	0.157	4.19	0.165	6.50	L	M		
LTML060H 08 LTMR060H 08			31.94	0.283	58	11.00	0.433	22.00	0.866	6.20	0.244	4.00	0.157	1.80	0.071	2.50	L	M		
LTML060L 06 LTMR060L 06			31.94	0.283	205	11.00	0.433	22.00	0.866	8.20	0.323	6.00	0.236	4.19	0.165	6.50	M	N		
LTML060L 08 LTMR060L 08			31.94	0.283	79	11.00	0.433	22.00	0.866	8.20	0.323	6.00	0.236	1.80	0.071	2.50	M	N		
LTL025E 06 LTR025E 06			0.64	0.025	47.45	0.420	360	12.70	0.500	25.40	1.000	8.26	0.325	5.54	0.218	6.99	0.275	9.50	L	M
LTL025E 08 LTR025E 08					47.45	0.420	360	15.88	0.625	31.75	1.250	12.57	0.495	9.12	0.359	4.11	0.162	5.50	M	N
LTL028E 06 LTR028E 06	0.71	0.028	62.14	0.550	360	12.70	0.500	25.40	1.000	9.02	0.355	6.22	0.245	7.75	0.305	9.50	M	P		
LTL028E 08 LTR028E 08			62.14	0.550	360	25.40	1.000	50.80	2.000	15.04	0.592	11.13	0.438	4.62	0.182	5.50	Q	R		
LTML075F 06 LTMR075F 06	0.75	0.030	58.84	0.521	90	12.50	0.492	25.00	0.984	5.00	0.197	3.00	0.118	5.26	0.207	6.50	L	M		
LTML075F 08 LTMR075F 08			58.84	0.521	35	12.50	0.492	25.00	0.984	5.00	0.197	3.00	0.118	2.26	0.089	2.50	L	M		
LTML075K 06 LTMR075K 06			58.84	0.521	143	12.50	0.492	25.00	0.984	7.50	0.295	5.00	0.197	5.26	0.207	6.50	L	M		
LTML075K 08 LTMR075K 08			58.84	0.521	55	12.50	0.492	25.00	0.984	7.50	0.295	5.00	0.197	2.26	0.089	2.50	L	M		
LTML075Q 06 LTMR075Q 06			58.84	0.521	207	12.50	0.492	25.00	0.984	10.50	0.413	8.00	0.315	5.26	0.207	6.50	M	N		
LTML075Q 08 LTMR075Q 08			58.84	0.521	80	12.50	0.492	25.00	0.984	10.50	0.413	8.00	0.315	2.26	0.089	2.50	M	N		
LTL030F 06 LTR030F 06			0.76	0.030	76.83	0.680	360	12.70	0.500	25.40	1.000	10.41	0.410	6.35	0.250	8.26	0.325	9.50	M	P
LTL030F 08 LTR030F 08					76.83	0.680	360	25.40	1.000	50.80	2.000	16.05	0.632	11.51	0.453	4.95	0.195	5.50	Q	Q
LTL032F 06 LTR032F 06	0.81	0.032	98.86	0.875	360	12.70	0.500	25.40	1.000	9.70	0.382	6.35	0.250	8.76	0.345	9.50	M	P		
LTL032F 08 LTR032F 08			98.86	0.875	360	25.40	1.000	50.80	2.000	16.18	0.637	11.91	0.469	5.28	0.208	5.50	R	S		
LTL035G 06 LTR035G 06	0.89	0.035	120.89	1.070	360	15.88	0.625	31.75	1.250	11.99	0.472	7.92	0.312	9.65	0.380	9.50	N	P		
LTL035G 08 LTR035G 08			120.89	1.070	360	25.40	1.000	50.80	2.000	18.87	0.743	13.89	0.547	5.79	0.228	5.50	U	V		
LTL038G 06 LTR038G 06	0.97	0.038	144.62	1.280	360	15.88	0.625	31.75	1.250	13.06	0.514	9.02	0.355	10.41	0.410	9.50	N	P		
LTL038G 08 LTR038G 08			144.62	1.280	360	25.40	1.000	50.80	2.000	21.87	0.861	15.88	0.625	6.27	0.247	5.50	X	Z		
LTML100J 06 LTMR100J 06	1.00	0.039	136.12	1.205	93	17.50	0.689	35.00	1.378	7.00	0.276	4.00	0.157	7.01	0.276	6.50	L	M		
LTML100J 08 LTMR100J 08			136.12	1.205	36	17.50	0.689	35.00	1.378	7.00	0.276	4.00	0.157	3.00	0.118	2.50	L	M		
LTML100N 06 LTMR100N 06			136.12	1.205	124	17.50	0.689	35.00	1.378	9.00	0.354	6.00	0.236	7.01	0.276	6.50	M	N		
LTML100N 08 LTMR100N 08			136.12	1.205	48	17.50	0.689	35.00	1.378	9.00	0.354	6.00	0.236	3.00	0.118	2.50	M	N		
LTML100T 06 LTMR100T 06			136.12	1.205	201	17.50	0.689	35.00	1.378	14.00	0.551	10.00	0.394	7.01	0.276	6.50	P	R		
LTML100T 08 LTMR100T 08			136.12	1.205	77	17.50	0.689	35.00	1.378	14.00	0.551	10.00	0.394	3.00	0.118	2.50	N	P		



TORSION SPRINGS

● Left Hand or Right Helix

● Music Wire (Plated) or Stainless Steel (Passivated)

LEE STOCK NUMBER	NOMINAL WIRE DIAMETER		(T) MAXIMUM TORQUE (see footnotes)		DEFLECTION TO MAX. TORQUE	(R) RADIUS		(A) LENGTH OF LEG		OUTSIDE DIAMETER		SUGGESTED MANDREL SIZE		(L) BODY LENGTH APPROX.		TOTAL NO. OF COILS	PRICE LIST			
	MM	IN	N-MM	IN-LB		DEG (°)	MM	IN	MM	IN	MM	IN	MM	IN	MM		IN	Music Wire	302 Stainless	
																	M	S		
LTL040H 06 LTR040H 06	1.02	0.040	169.48	1.500	360	25.40	1.000	50.80	2.000	12.90	0.508	8.71	0.343	11.94	0.470	10.50	N	P		
LTL040H 08 LTR040H 08			169.48	1.500						360	25.40	1.000	50.80	2.000	17.07	0.672	12.70	0.500	8.64	0.340
LTL045H 06 LTR045H 06	1.14	0.045	242.92	2.150	360	25.40	1.000	50.80	2.000	13.94	0.549	9.53	0.375	13.46	0.530	10.50	N	P		
LTL045H 08 LTR045H 08			242.92	2.150						360	25.40	1.000	50.80	2.000	19.08	0.751	14.27	0.562	9.70	0.382
LTL048J 06 LTR048J 06	1.22	0.048	310.71	2.750	360	25.40	1.000	50.80	2.000	15.11	0.595	10.31	0.406	14.48	0.570	10.50	Q	R		
LTL048J 08 LTR048J 08			310.71	2.750						360	25.40	1.000	50.80	2.000	19.38	0.763	14.27	0.562	10.36	0.408
LTML125M 06 LTMR125M 06	1.25	0.049	255.09	2.258	87	20.00	0.787	40.00	1.575	8.50	0.335	5.00	0.197	8.74	0.344	6.50	M	N		
LTML125M 08 LTMR125M 08			255.09	2.258	33	20.00	0.787	40.00	1.575	8.50	0.335	5.00	0.197	3.76	0.148	2.50	M	N		
LTML125R 06 LTMR125R 06			255.09	2.258	123	20.00	0.787	40.00	1.575	11.50	0.453	8.00	0.315	8.74	0.344	6.50	M	N		
LTML125R 08 LTMR125R 08			255.09	2.258	47	20.00	0.787	40.00	1.575	11.50	0.453	8.00	0.315	3.76	0.148	2.50	M	N		
LTML125V 06 LTMR125V 06			255.09	2.258	182	20.00	0.787	40.00	1.575	16.50	0.650	12.00	0.472	8.74	0.344	6.50	S	T		
LTML125V 08 LTMR125V 08			255.09	2.258	70	20.00	0.787	40.00	1.575	16.50	0.650	12.00	0.472	3.76	0.148	2.50	S	T		
LTL051J 06 LTR051J 06			1.30	0.051	350.25	3.100	360	25.40	1.000	50.80	2.000	15.95	0.628	11.10	0.437	15.24	0.600	10.50	Q	R
LTL051J 08 LTR051J 08					350.25	3.100						360	25.40	1.000	50.80	2.000	21.82	0.859	16.28	0.641
LTL054K 06 LTR054K 06	1.37	0.054	395.45	3.500	360	25.40	1.000	50.80	2.000	17.63	0.694	12.70	0.500	17.53	0.690	11.50	S	T		
LTL054K 08 LTR054K 08			395.45	3.500						360	25.40	1.000	50.80	2.000	21.54	0.848	16.28	0.641	13.03	0.513
LTL059K 06 LTR059K 06	1.50	0.059	508.43	4.500	360	25.40	1.000	50.80	2.000	18.01	0.709	12.45	0.490	19.05	0.750	11.50	T	V		
LTL059K 08 LTR059K 08			508.43	4.500						360	25.40	1.000	50.80	2.000	23.85	0.939	17.86	0.703	14.22	0.560
LTML150P 06 LTMR150P 06			425.51	3.767	82	22.50	0.886	45.00	1.772	10.00	0.394	6.00	0.236	10.49	0.413	6.50	M	N		
LTML150P 08 LTMR150P 08			425.51	3.767	31	22.50	0.886	45.00	1.772	10.00	0.394	6.00	0.236	4.50	0.177	2.50	M	N		
LTML150U 06 LTMR150U 06			425.51	3.767	130	22.50	0.886	45.00	1.772	15.00	0.591	10.00	0.394	10.49	0.413	6.50	R	S		
LTML150U 08 LTMR150U 08			425.51	3.767	50	22.50	0.886	45.00	1.772	15.00	0.591	10.00	0.394	4.50	0.177	2.50	Q	R		
LTML150X 06 LTMR150X 06			425.51	3.767	178	22.50	0.886	45.00	1.772	20.00	0.787	15.00	0.591	10.49	0.413	6.50	V	X		
LTML150X 08 LTMR150X 08			425.51	3.767	68	22.50	0.886	45.00	1.772	20.00	0.787	15.00	0.591	4.50	0.177	2.50	U	W		
LTL063L 08 LTR063L 08	1.52	0.060	621.42	5.500	360	25.40	1.000	50.80	2.000	21.08	0.830	15.47	0.609	14.48	0.570	8.50	W	Y		
LTL063L 06 LTR063L 06	1.60	0.063	621.42	5.500	360	25.40	1.000	50.80	2.000	20.27	0.798	14.68	0.578	20.02	0.788	11.50	V	X		
LTL070M 06 LTR070M 06	1.78	0.070	847.39	7.500	360	25.40	1.000	50.80	2.000	21.41	0.843	15.06	0.593	22.61	0.890	11.50	X	Z		
LTL070M 08 LTR070M 08			847.39	7.500						360	38.10	1.500	76.20	3.000	28.35	1.116	21.44	0.844	16.89	0.665
LTL075M 06 LTR075M 06	1.91	0.075	1039.80	9.203	360	25.40	1.000	50.80	2.000	25.02	0.985	16.76	0.660	22.35	0.880	10.50	Z	BB		
LTL075M 08 LTR075M 08			1039.80	9.203						360	44.45	1.750	88.90	3.500	34.24	1.348	25.81	1.016	16.21	0.638

TORSION SPRINGS



● Left Hand or Right Helix

● Music Wire (Plated) or Stainless Steel (Passivated)

LEE STOCK NUMBER	NOMINAL WIRE DIAMETER		(T) MAXIMUM TORQUE (see footnotes)		DEFLECTION TO MAX. TORQUE DEG (°)	(R) RADIUS		(A) LENGTH OF LEG		OUTSIDE DIAMETER		SUGGESTED MANDREL SIZE		(L) BODY LENGTH APPROX.		TOTAL NO. OF COILS	PRICE LIST			
	MM	IN	N-MM	IN-LB		MM	IN	MM	IN	MM	IN	MM	IN	MM	IN		Music Wire	302 Stainless		
																		M	S	
LTL078N 06 LTR078N 06	1.98	0.078	1180.69	10.450	360	25.40	1.000	50.80	2.000	25.78	1.015	19.05	0.750	22.78	0.897	10.50	BB	BD		
LTL078N 08 LTR078N 08			1180.69	10.450		360	44.45	1.750	88.90	3.500	35.31	1.390	26.59	1.047	16.84		0.663	7.50	BC	BE
LTML200S 06 LTMR200S 06	2.00	0.079	978.56	8.663	77	30.00	1.181	60.00	2.362	13.00	0.512	8.00	0.315	14.00	0.551	6.50	P	Q		
LTML200S 08 LTMR200S 08			978.56	8.663		30	30.00	1.181	60.00	2.362	13.00	0.512	8.00	0.315	5.99		0.236	2.50	N	P
LTML200W 06 LTMR200W 06			978.56	8.663	112	30.00	1.181	60.00	2.362	18.00	0.709	12.00	0.472	14.00	0.551	6.50	V	X		
LTML200W 08 LTMR200W 08			978.56	8.663		43	30.00	1.181	60.00	2.362	18.00	0.709	12.00	0.472	5.99		0.236	2.50	U	W
LTML200Y 06 LTMR200Y 06			978.56	8.663	175	30.00	1.181	60.00	2.362	27.00	1.063	20.00	0.787	14.00	0.551	6.50	Y	BA		
LTML200Y 08 LTMR200Y 08			978.56	8.663		67	30.00	1.181	60.00	2.362	27.00	1.063	20.00	0.787	5.99		0.236	2.50	X	X
LTL085N 06 LTR085N 06			2.16	0.085	1453.10	12.861	360	31.75	1.250	63.50	2.500	27.08	1.066	19.84	0.781	27.00	1.063	11.50	BD	BF
LTL085N 08 LTR085N 08					1452.98	12.860		360	50.80	2.000	101.60	4.000	35.86	1.412	27.38	1.078	20.52		0.808	8.50
LTL095P 06 LTR095P 06	2.41	0.095	1937.46	17.148	360	38.10	1.500	76.20	3.000	31.57	1.243	22.23	0.875	30.18	1.188	11.50	BF	BH		
LTL095P 08 LTR095P 08			1936.56	17.140		360	50.80	2.000	101.60	4.000	41.86	1.648	31.75	1.250	22.91		0.902	8.50	BG	BJ
LTL105Q 06 LTR105Q 06	2.67	0.105	2372.68	21.000	360	44.45	1.750	88.90	3.500	34.77	1.369	23.01	0.906	36.00	1.418	12.50	BF	BH		
LTL105Q 08 LTR105Q 08			2372.68	21.000		360	50.80	2.000	101.60	4.000	45.64	1.797	34.93	1.375	27.99		1.102	9.50	BG	BJ
LTL115R 06 LTR115R 06	2.92	0.115	3163.58	28.000	360	50.80	2.000	101.60	4.000	37.21	1.465	24.61	0.969	39.43	1.553	12.50	BG	BJ		
LTL115R 08 LTR115R 08			3163.58	28.000		360	50.80	2.000	101.60	4.000	49.30	1.941	37.69	1.484	30.68		1.208	9.50	BH	BK
LTL125S 06 LTR125S 06	3.18	0.125	3615.51	32.000	360	50.80	2.000	101.60	4.000	40.77	1.605	27.53	1.084	49.21	1.938	14.50	BH	BK		
LTL125S 08 LTR125S 08			3615.51	32.000		360	50.80	2.000	101.60	4.000	49.99	1.968	38.51	1.516	39.67		1.562	11.50	BJ	BL
LTL135T 06 LTR135T 06	3.43	0.135	4519.39	40.000	360	50.80	2.000	101.60	4.000	44.58	1.755	30.18	1.188	53.15	2.093	14.50	BK	BM		
LTL135T 08 LTR135T 08			4519.39	40.000		360	53.98	2.125	107.95	4.250	54.38	2.141	42.06	1.656	42.88		1.688	11.50	BL	BP